



# SRT RADIO MODEM SETUP, INSTALLATION, OPERATION & PROGRAMMING MANUAL



## SRT150, SRT450 & SRT950 RADIO MODEMS

## CONTENTS

<b>1.0</b>	<b>INTRODCUTION</b>
1.1	PRODUCTS COVERED
1.2	IMPORTANT NOTICES
1.2.1	COPYRIGHT
1.2.2	RIGHT TO CHANGE
1.2.3	SOFTWARE
1.2.4	SAFETY CRITICAL APPLICATIONS
1.2.5	USE
1.3	OVERVIEW
1.3.1	TRANSMITTER
1.3.2	RECEIVER
1.3.4	MPU CONTROL & INTERFACE BOARD
1.3.5	PROCESSOR FIRMWARE/SOFTWARE
1.4	CUSTOM SOFTWARE
1.5	CONTINUOUS DEVELOPMENT
1.6	PROGRAMMING
1.7	CHANNEL SELECTION:
1.8	SOFT MODEM:
1.9	FORWARD ERROR CORRECTION (FEC)
1.10	POWER SAVE MODE:
1.10.1	Internal Power Save Mode
1.10.2	External Power Save Mode
1.11	“RSSI” RECEIVE SIGNAL STRENGTH INDICATION:
1.12	STATUS LED’s:
1.13	RF POWER:
1.14	TX TIME-OUT-TIMER:
1.15	REMOTE OPERATION DURING SETUP:
1.16	SQUELCH TAIL ELIMINATION
1.17	MODES OF OPERATION & PROTOCOL HANDLING:
1.17.1	Radio Modem Modes of Operation
1.17.1.1	Dumb modem
1.17.1.2	Protocol specific modem
1.17.1.3	Routing modem
1.17.1.4	Dial up modem
1.17.2	Modes of Operation of connected Input/Output (I.O.) modules
1.17.2.1	Isolated network with point to point I/O mapping
1.17.2.2	Network with retrieved data access at base station.
1.17.2.3	Externally controlled network
1.18	PROGRAMMING SERVICE & MANAGEMENT SOFTWARE
1.18.1	Programming software:
1.18.2	Service Software
1.18.3	Custom Software
1.18.4	Network Management Software
1.19	OPTIONS AND ACCESSORIES:
1.19.1	DIN Mountable RF Power Amplifier
1.19.2	DIN I.O. Modules:
1.19.3	Enclosures:
1.19.4	Manuals & Connecting leads

## **2.1 TECHNICAL SPECIFICATIONS**

- 2.1.1 General
- 2.1.2 Transmitter:
- 2.1.3 Receiver:
- 2.1.4 Internal Modem
- 2.1.5 Bit Error Rate BER
- 2.2 APPROVALS AND LICENSING
  - 2.2.1 UK Approvals
  - 2.2.2 European Approvals
  - 2.2.3 Other Approvals

## **3.0 SET-UP AND INTERFACE DESCRIPTION**

- 3.1 INTERNAL LINKS
- 3.2 FIRMWARE DOWNLOAD PORT
- 3.3 RS232 & 5VTTL SERIAL INTERFACE
  - 3.3.1 RS485 CONNECTION
  - 3.3.2 Serial Port Pin Connections
- 3.4 12VDC POWER
- 3.5 I2C INTERNAL & EXTERNAL BUS
- 3.6 SWITCHES
- 3.7 PROGRAMMING
- 3.8 CHANNEL SELECTION
- 3.9 RF POWER:
- 3.10 INTERNAL MODEM
- 3.11 FORWARD ERROR CORRECTION
- 3.12 SQUELCH TAIL (DRIBBLE BITS) ELIMINATION
- 3.13 STATUS LED's:
  - 3.13.1 System led
  - 3.13.2 Error Number
- 3.14 TIME-OUT-TIMER
- 3.15 POWER CONSUMPTION
  - 3.15.1 Transmitter RF power verses current
- 3.16 POWER SAVE MODE:
  - 3.16.1 INTERNAL POWER SAVE
  - 3.16.2 EXTERNAL POWER SAVE
- 3.17 "RSSI" RECEIVE SIGNAL STRENGTH INDICATION

## **4.0 DIGITAL MODES OF OPERATION & PROTOCOLS**

- 4.1 SERIAL INTERFACE & TRANSMISSION
  - 4.1.1 TRANSMISSION USING RTS/CTS HANDSHAKING
  - 4.1.2 TRANSMISSION WITHOUT HARDWARE HANDSHAKE
  - 4.1.3 DATA RECEPTION
- 4.2 TRANSMIT & RECEIVE TIMING
  - 4.2.1 RECEIVE TO TRANSMIT SWITCHING TIME

- 4.2.2 MESSAGE DURATION
- 4.2.3 TRANSMIT TO RECEIVE SWITCHING TIME
- 4.3 RADIO DATA FORMATS
- 4.3.1 SYNCHRONOUS/ ASYNCHRONOUS TRANSMISSION FORMAT
- 4.4 OPERATING MODES
- 4.4.1 TRANSPARENT MODE
- 4.4.2 PROTOCOL SPECIFIC MODE
- 4.4.3 ROUTING MODE
- 4.4.4 DIAL UP MODE
- 4.5 STORE & FORWARD
- 4.6 STORE & FORWARD BASED ON A CLIENTS PROTOCOL.
- 4.7 HAYES AT MODE
- 4.7.1 AT COMMAND SUMMARY
- 4.7.2 SERIAL PORT HANDSHAKING WITH HAYES AT MODE
- 4.7.3 POWER SAVING
- 4.7.4 PROGRAMMING PRECAUTION
- 4.7.5 CALL SET UP PROCEDURE
- 4.7.6 RADIO ROUTING
- 4.7.7 IMPLEMENTED S REGISTERS
- 4.8 MODBUS
- 4.8.1 SETTING UP MODBUS OPERATION
- 4.8.2 MODBUS OPERATION
- 4.8.3 POWER SAVE OPERATION WITH MODBUS
- 4.8.4 SERIAL PORT HANDSHAKING WITH MODBUS
- 4.8.5 TIMEOUTS IN MODBUS MODES
- 4.9 RFT ROUTING PROTOCOL
- 4.9.1 SETTING UP RFT ROUTING OPERATION
- 4.9.2 POWER SAVE OPERATION WITH RFT ROUTING
- 4.9.3 SERIAL PORT HANDSHAKING WITH RFT ROUTING
- 4.9.4 TIMEOUTS IN RFT ROUTING MODE

## **5.0 PROGRAMMING**

- 5.1 INTRODUCTION
- 5.2 SRP PROGRAMMING SOFTWARE VERSIONS
- 5.3 CONFIGURATION OF THE SRP PROGRAM
- 5.4 STARTING THE PROGRAM.
- 5.5 LOCAL PC PROGRAMMING
- 5.6 OPENING MENU
- 5.6.1 PROGRAMME VERSION NUMBER & COMPATIBILITY MESSAGE
- 5.6.2 PROGRAME RADIO/READ RADIO
- 5.6.3 LOAD PROGRAM FROM DISC
- 5.6.4 SAVE PROGRAM TO DISC
- 5.6.5 EDIT NOTES
- 5.6.6 PRINT PROGRAM
- 5.6.7 ERASE PROGRAM
- 5.6.8 CALIBRATE
- 5.6.9 NETWORK MANAGEMENT (OPTION)
- 5.6.10 QUIT

5.7	DESCRIPTION OF MAIN MENU EDIT FUNCTIONS:
5.7.1	MAIN MENU
5.7.2	FREQUENCY RANGE
5.7.3	ALIGNMENT RANGE
5.7.4	CHANNEL SELECTION MODE
5.7.4.1	Number of Channels
5.7.4.2	Channel Increments
5.7.4.3	RX Start Frequency
5.7.4.4	TX Start Frequency
5.7.5	POWER RANGE
5.7.6	TX POWER
5.7.7	POWER SAVE OPTIONS
5.7.7.1	Save On Time
5.7.7.2	Save Off Time
5.7.7.3	Save Resume Time
5.7.8	SERIAL NUMBER
5.7.9	NOTE PAD
5.7.10	LOCKOUT TIME MODE
5.7.11	LOCKOUT TIME
5.7.12	MENU OPTIONS
5.7.12.1	Return to Main Menu
5.7.12.2	Edit Channel Data
5.7.12.3	Edit Modem/Interface
5.7.13	LEADOUT DELAY
5.8	MODEM/INTERFACE EDIT MENU
5.8.1	RADIO BAUD RATE
5.8.2	RADIO DATA BITS
5.8.3	RADIO PARITY
5.8.4	RADIO STOP BITS
5.8.5	FFSK TONE SET
5.8.6	FFSK SYNC/ASYN
5.8.7	SERIAL BAUD RATE
5.8.8	SERIAL DATA BITS
5.8.9	SERIAL PARITY
5.8.10	SERIAL STOP BITS
5.8.11	RTS/CTS HANSHAKE
5.8.12	DCD OPERATION
5.8.13	DTR SHUTDOWN
5.8.14	LEAD IN DELAY
5.8.15	LEAD OUT DELAY
5.8.16.	INTERFACE PROTOCOL
5.8.17	MESSAGE PACKETING
5.8.18	FORWARD ERROR CORRECTION
5.8.19	NETWORK I.D. ADDRESS
5.8.20	RADIO ADDRESS
5.9	HAYES "AT" SELECTION
5.9.1	AUTO ANSWER TIME (s)
5.9.2	ESC CHARACTER CODE
5.9.3	ESC GUARD TIME (mS)
5.9.4	MIN & MAX PWR SAVE ADDRESS
5.9.5	HOST INACTIVITY TIME

5.10	MODBUS SELECTION
5.10.1	INTERFACE PROTOCOL
5.10.2	FORWARD ERROR CORRECTION
5.10.3	NETWORK I.D.
5.10.4	RADIO ADDRESS
5.10.5	MIN & MAX PWR SAVE ADDRESS
5.10.6	ROUTING TABLE
5.10.7	EDIT ROUTING TABLE
5.11	ROUTING TABLE MENU
5.12	RFT ROUTING SELECTION
5.12.1	INTERFACE PROTOCOL
5.12.2	FORWARD ERROR CORRECTION
5.12.3	NETWORK I.D.
5.12.4	RADIO ADDRESS
5.12.5	ADDRESS OFFSET
5.12.6	MIN & MAX PWR SAVE ADDRESS
5.12.7	ROUTING TABLE
5.12.8	EDIT ROUTING TABLE
5.12.9	RFT ROUTING TABLE MENU
5.13	EDIT CHANNEL DATA SCREEN
5.13.2	DESCRIPTION OF CHANNEL DATA MENU FUNCTIONS:
5.13.3	RX & TX FREQUENCY
5.13.4	NEXT/PREVIOUS CHANNEL
5.13.5	EDITING CHANNEL
5.14	CALIBRATE MENU (FACTORY & SERVICE CENTRE OPTION)
5.14.1	TEST MAX POWER/MOD BALANCE
5.14.2	SET TX FREQUENCY
5.14.3	SET RX FREQUENCY
5.14.4	CALIBRATE POWER
5.14.5	SET PEAK DEVIATION
5.14.6	CAL RSSI
5.14.7	RSSI TEST
5.14.8	RETURN TO MAIN MENU
5.15	NETWORK MANAGMENT
5.15.1	DESTINATION RADIO
5.15.2	1 <sup>st</sup> - 6 <sup>th</sup> RELAYS
5.15.3	PROGRAM RADIO
5.15.4	READ RADIO
5.15.5	EDIT PROGRAM
5.15.6	ROUTE DIAGNOSTICS (Available on the ART only)
5.15.7	TUNE ALL RADIOS (Available on the ART only)
5.15.8	REMOTE FIRMWARE DOWNLOAD (Available on the ART only)
5.15.9	RETURN TO MAIN EDIT MENU

## **6.0           INSTALLATION**

6.1	INTRODUCTION
6.2	POWER SUPPLIES
6.3	EFFECTIVE RADIATED POWER (ERP)

6.4	ANTENNAS, COAX FEEDERS & PERIPHERALS
6.4.1	ANTENNAS
6.4.2	TYPES OF ANTENNAS
6.4.3	DIRECTIONAL ANTENNAS
6.4.4	OMNI-DIRECTIONAL ANTENNAS
6.4.5	PATCH OR PLATE ANTENNAS
6.4.6	ANTENNA MOUNTING
6.4.7	POLARISATION
6.4.8	ALIGNMENT
6.4.9	ANTENNA COAX FEEDER:
6.4.10	SIGNAL LOSS VERSES CABLE LENGTH AT 500MHZ
6.4.11	COAX, CONNECTORS:
6.4.12	VSWR MEASUREMENT:
6.4.13	Lightning Arresters
6.5	MOUNTING & INSTALLATION
6.5.1	SRT DIMENSIONS
6.5.2	SRT MOUNTING
6.5.3	ANTENNA CONNECTION THROUGH AN ENCLOSURE:
6.5.4	WALL MOUNTING ENCLOSURE

## **1.1 PRODUCTS COVERED**

This Manual covers the SRT Series of low current, high performance Radio Modems designed for portable, mobile or fixed data application in commercial and industrial systems.

Information is provided to configure, program, install, and operate the products in various applications. Point to point, point to multi-point and networks can be accommodated by selecting one of the following modes; transparent, Hays AT commands, RFT routing or MODBUS, at the time of the document IEC870 & DNP3 are under development

With the built-in test software, first line "Go-No Go" testing can be easily performed. Component level servicing is not covered in this document; if the product fails its first line testing it should be returned to a service centre.

## **1.2 IMPORTANT NOTICES**

### **1.2.1 COPYRIGHT**

All rights to this manual are the sole property of R.F. Technologies Ltd, The copying of the manual in whole or in part by any method without written permission is strictly prohibited.

### **1.2.2 RIGHT TO CHANGE**

In the interest of improvement, R.F. Technologies reserves the right to change the technical specifications or functions of its product without notice.

### **1.2.3 SOFTWARE**

R.F. Technologies Ltd software is delivered "as is". R.F. technologies Ltd does not grant any kind of warranty or guarantees on its saleability or it's suitability for use in specific applications.

Under no circumstances is R.F. Technologies liable for any damages arising from using the software.

The copyrights relating to all software is the sole property of R.F. Technologies Ltd

Any coping, editing, translating or modifying is strictly forbidden without prior written consent from R.F. Technologies Ltd

### **1.2.4 SAFETY CRITICAL APPLICATIONS**

The SRT series have not been designed for or intended for use in safety critical or life support applications. No functional warranty is given if the product is used in such applications.

### **1.2.5 USE**

The SRT radio modems have been designed to work on various licensed and license free frequency bands in use around the world. The user must ensure that the radio modem is used under the terms & license conditions in the license free bands.

In licensed bands, the user must obtain permission and the necessary licenses from the local authorities. For further information see section 2.2.

## **1.3 OVERVIEW**

### **1.3.1 TRANSMITTER**

The transmitter can be programmed anywhere within a pre-aligned bandwidth, which is within a wider tuneable F band, details of the bandwidths are in the technical specifications. Both High power (50mW - 5Watts) and low power (10mW - 1Watt) products are available. For higher power an external RF amplifier can be added.

### **1.3.2 RECEIVER**

The receiver is a very low current double conversion superheterodyne with an active balanced mixer for very good intermodulation. Careful attention to spurious response, adjacent channel and blocking performance, makes the product ideal for crowded telemetry channels.

To achieve the high performance the programmable bandwidth of the receiver has been limited (for UHF it is 12MHz,  $\pm$  6MHz from centre frequency), full details are in the technical specification section.

Should re-alignment be required, the unit can be returned to our service centre, or with proper test equipment, a qualified engineer can follow the alignment procedure in our Technical Manual.

### **1.3.4 MPU CONTROL & INTERFACE BOARD**

The Microprocessor (MPU) control & interface board is the heart of the product and at the centre is a 128K flash microprocessor that controls all the interface circuits to the radio modules and external Input/outputs. As well as the control functions, the processor provides DSP functionality that enables full duplex modem operation between 150 - 9600bps with the option of FEC at 9600bps.

The board contains all necessary electronic potentiometers for full remote alignment and control, these settings and other parameters are stored within the MPU's non-volatile EEPROM.

### **1.3.5 PROCESSOR FIRMWARE/SOFTWARE**

The processor has 128K of flash memory from which the code is executed and internal EEPROM for storing programmed parameters. As only about 50% of the memory space is used at the moment, there is plenty of space for future upgrades and custom applications.

## **1.4 CUSTOM SOFTWARE**

Custom software or protocols for specific client applications, can be written and included as PC programmable options in relatively short time scales and normally at nominal costs. Further details can be obtained from the sales office.

## **1.5 CONTINUOUS DEVELOPMENT**

The SRT series has been designed with continuous development in mind and with less than 50% of the code space currently in use, there is plenty of room for protocols such as TCP/IP

## **1.6 PROGRAMMING**

Apart from internal factory set-up links, all the parameters of the SRT Series are PC

programmable via the serial port or over the radio link via a special secure mode. Programs are available in DOS or Windows software, full details of all the programmable parameters are covered in the Programming section of this manual. For additional memory space (should it be required) a piggy back memory board with a further 512k is available to download new code to the processor. Once deployed in the field, changes and upgrades to the firmware can easily be sent over the radio link via our secure over air programming protocol.

### **1.7 CHANNEL SELECTION:**

The SRT Series is PC programmed with up to 80 simplex or semi-duplex channels. Once programmed, channels can then be selected via rotary switches on the front pane, from a PC program via the serial port or over the radio link with the aid of our secure management software.

### **1.8 SOFT MODEM:**

The SRT Radio Modem has a "soft modem" which offers unparalleled performance and flexibility over a wide range of speeds and formats and enables future formats to be downloaded from a PC or over the air. Within a 12.5KHz channel, the unit can be programmed for 150-2400bps FSK/FFSK with Bell202 & V23 supported, 4800bps GMSK & 9600bps 4 Level FSK.

### **1.9 FORWARD ERROR CORRECTION (FEC)**

Forward error correction is available as a programmable option at 9600bps, but it should be noted that there is an overhead with any FEC. The overhead in the SRT effectively reduces the Data speed to about 6300bps.

### **1.10 POWER SAVE MODE:**

The SRT Series has both internal and external power save modes.

#### **1.10.1 Internal Power Save Mode**

The microprocessor controls the on/off function of the receiver and after a pre-programmed time the MPU will switch on the receiver to look for a carrier. If a carrier is not detected then the transceiver goes back into sleep mode. If during the time the transceiver is awake a carrier is received, the unit will stay awake. After the carrier drops out, the receiver will stay awake until the programmed resume time elapses. Once the resume time has elapsed the transceiver will go back into sleep mode. The save ON/OFF and\_resume time are all programmable via the PC program.

#### **1.10.2 External Power Save Mode**

In the external mode the ON/OFF function of the modem is controlled by the host via the DTR line.

### **1.11 "RSSI" RECEIVE SIGNAL STRENGTH INDICATION:**

Each SRT has an individually calibrated RSSI output which is accurately measured by an internal A-D converter. The signal strength can then be read in dB microvolts on a PC connected to the serial port.

### **1.12 STATUS LED's:**

The SRT Radio Modems have 11 LED's to enable the operator to see at a glance the status of the product and the serial port in operation or on test.

### **1.13 RF POWER:**

The SRT Series is available in two power ranges: 10mW to 1 Watt for ultra low power requirement, and 20mW to 5 Watts. There are no internal power adjustment points inside the modem; the RF power level is PC and over air programmable directly in Watts & Milliwatts with an accuracy of +/-1dB.

### **1.14 TX TIME-OUT-TIMER:**

The transmitter within the SRT has a time-out-timer which allows the maximum continuous transmission time to be set in order to prevent channel blocking due to a to fault. The timer operates in all modes and can be programmed in one second steps between 0 and 255 seconds. If programmed and the time is exceeded, transmission will cease until the action that normally causes transmission is removed and then re-applied. If not required the timer can be programmed off.

### **1.15 REMOTE OPERATION DURING SETUP:**

When the SRT is programmed for remote set-up, the RF power level can be remotely changed over the link. Once the link is established the receiver RSSI values at either the outstation or base station can be requested, so the RF power and antenna can be adjusted for optimum link performance.

### **1.16 SQUELCH TAIL ELIMINATION**

For old or non tolerant protocols, where the presence of a mute (Squelch) tail may cause a problem at the end of a message, a simple packetising option can be enabled.

### **1.17 MODES OF OPERATION & PROTOCOL HANDLING:**

#### **1.17.1 Radio Modem Modes of Operation**

The basic modes of operation of the radio modem are as follows:

##### **1.17.1.1 Dumb modem**

The radio has no knowledge of the data it is transmitting, data is simply transmitted and received under hardware control with the option of RTS control or initiation of transmit after receipt of serial data, with CTS providing an optional flow control.

This configuration is useful when expanding older systems where the radios must be compatible with others of a different manufacture.

##### **1.17.1.2 Protocol specific modem**

The radio recognises a complete frame and only transmits and receives data conforming to that format. No addressing of radios or routing of data is performed. Protocols such as MODBUS & DNP3 can be supported in this way.

##### **1.17.1.3 Routing modem**

The radios recognise a protocol specific frame and the address to which the frame is to be sent. Routing information must be stored in each radio for each destination address that requires the use of repeaters. Any radio in the system can operate as a repeater. The radio does not perform any acknowledgement or retries. Any protocol using a fixed address field such as MODBUS can be supported.

##### **1.17.1.4 Dial up modem**

Hayes protocol is used to dial up the radio link which may include repeaters or store & forward stations; the route information is not stored but is passed in the dial up command in the form of a telephone number, once the link is established it is transparent and so independent of the protocol being transported. This allows point to point protocols such as

SLIP and PPP (and hence TCP/IP) to be conveyed. Dial up is less efficient for small data transactions because of the data transactions carried out during the connect and disconnect phases.

## **1.17.2 Modes of Operation of connected Input/Output (I.O.) modules**

### **1.17.2.1 Isolated network with point to point I/O mapping**

Inputs and outputs at outstations are mapped to corresponding outputs and inputs at the master.

### **1.17.2.2 Network with retrieved data access at base station.**

Instead of mapping data to physical inputs and outputs at the master, data is exchanged in memory. The memory is accessible using MODBUS. The base station carries out its data retrieval process independently of the MODBUS accesses.

### **1.17.2.3 Externally controlled network**

In this mode the base station only carries out data retrieval when requested to do so by the MODBUS interface.

The above modes are not independent processes but are run according to set up, it is possible to configure operation to be a mix of all three. E.g. some physical I/O might be desirable at the base station whilst the rest is passed by MODBUS, the base station can be set to keep polling independently in order to maintain the physical I/O but can also mix in commands passed by MODBUS

## **1.18 PROGRAMMING SERVICE & MANAGEMENT SOFTWARE**

Dedicated PC software packages have been written that provide unrivalled versatility combined with ease of use to the user.

### **1.18.1 Programming software:**

Programming software in DOS and Windows 95/98 is available for the SRT Series

### **1.18.2 Service Software**

Service software is available to enable competent engineers to perform first line testing of the product and re-alignment when used in conjunction with suitable test equipment.

### **1.18.3 Custom Software**

Custom software can be written for user specific applications, further details are available on request.

### **1.18.4 Network Management Software**

Network management software provides the user with direct access to the radio modems, for diagnostics, programming & re-programming, safe downloading of new firmware and the for the retrieval of data. All products on the I2C bus can be accessed in the same way.

## **1.19 OPTIONS AND ACCESSORIES:**

### **1.19.1 DIN Mountable RF Power Amplifier**

ART400PA-25 UHF 5Watt to 25Watt RF power amplifier with built-in VSWR facility that measures Forward & Reflected power and conveys the information back to the SRT via the I2C bus.

ART170PA-25 VHF 5Watt to 25Watt RF power amplifier as the ART400PA-25

### **1.19.2 DIN I.O. Modules:**

ART700 General purpose logger

ART710 8 Digital I.O.

ART720 4 12bit Analogue Outputs Current

ART721 4 12bit Analogue Outputs Voltage

ART730 4 12bit Analogue Inputs Current or Voltage

ART740 4 Digital I.O. 2 12bit Analogue Inputs, 2 12bit Analogue Outputs

ART780 I2C Protocol converter to Modbus, Canbus, Device-net etc.

ART781 2 x RS232/485 to I2C Bus converter

ART782 GPS module

### **1.19.3 Enclosures:**

Lockable IP51 wall cabinet to take an SRT, power supply and backup battery.

### **1.19.4 Manuals & Connecting leads**

Programming, installation and operations manual

2

# SPECIFICATIONS

## 2.1 TECHNICAL SPECIFICATIONS

### 2.1.1 General

Frequency Range:	SRT170	138 - 175MHz
	SRT380	350 - 406MHz
	SRT470	406 - 512MHz
	SRT970	820 - 950MHz
Power Requirements:	12VDC (10V - 15.5DC)	
	Standby:	< 75uA
	Receiver on & decoding:	<70mA
	Transmitter:	Dependant on Power
Number of Channels:	80 user programmable frequencies	
Min. Programmable Channel Step:	6.25 or 5KHz	
Channel Spacing:	Available in 12.5KHz, 20KHz or 25KHz	
Operating Temp. Stability:	2ppm -30 to +60°C	
Construction:	Milled aluminium enclosure	
Size:	90mm W x 125mm L x 45mm H	
Mounting:	DIN rail, or can be screwed to a flat surface	
Weight:	550gms	
Connectors:	RS232:	9 Way "D" Type
	12VDC	2Way Klippon Type
	RF	BNC
Led Indicators:	TX, Busy, System, RXD, TXD, RTS, CTS, DCD,DTR,DSR,RI	
Approvals:	The products have been designed to meet the following approvals. UK RF: MPT1411, 1329 & 1328 European RF: ETS 300-220 ETS 300-113 Australian: AS4268.2-1995 USA: FCC Part 90/15 Canadian DOC European CE: IETS 300-683	

### 2.1.2 Transmitter:

RF Output Power:	1Watt unit:	10mW to 1 Watt
	5Watt unit:	50mW to 5Watts
Bandwidth:	Without alignment:	VHF 15MHz
		UHF 12MHz
		900MHz 20MHz
Modulation:	Programmable FFSK, 2 Level FSK, 4 level FSK & GMSK.	
Max. Deviation:	$\pm 7.5$ KHz max	
Adj. Channel Power:	>65dB	
Hum and Noise:	>-35dB	
Spurious Emissions:	< 250nW & 4nW in specified bands	
Rise Time:	< 10mS	

### 2.1.3 Receiver:

Sensitivity:	0.25uV for 12dB SINAD		
Bandwidth:	Without re-alignment	VHF 5MHz	
		UHF 10MHz	
		900MHz 20MHz	
Spurious Response:	> 70dB		
Blocking:	> 90dB relative to 1uV		
Intermodulation:	> 65dB		
Adjacent Channel:	> 65dB at 12.5KHz		
IF Frequencies:	45MHz and 455KHz		
Spurious Emissions:	< 2nW		
Mute Response Time:	< 3msec		

#### 2.1.4 Internal Modem

Serial Comms:	Asynchronous or Synchronous with custom software. Baud rate programmable between 150bps and 38400bps
Interface:	Selectable RS232 or 5V TTL plus inverted/non-inverted,
Parity:	Programmable odd, Even or None
NRZI:	On or Off
Stop bits:	Programmable 1 or 2
Data Bits:	Programmable 7 or 8
Synchronous/Async.	Programmable either up to 1200bps, above 1200bps synchronous
Signalling Formats:	Programmable V23, Bell202, up to 1200 baud, 2400 baud FFSK, 4800 baud GMSK, 9600 baud 4 level FSK.
Baud date:	150 - 9600bps within 12.5KHz
Bit Error Rate:	150 - 2400 baud, less than $1 \times 10^{-3}$ at -120dBm 4800 baud, less than $1 \times 10^{-3}$ at -117dBm 9600 baud, less than $1 \times 10^{-3}$ at -112dBm

#### 2.1.5 Bit Error Rate BER

The Bit error rate quoted in the specification is for fixed messages with no Forward Error Correction (FEC) and represents that which will be obtained from typical data sent over the link. The BER should not be compared with other manufactures figures unless the data format is known, as many manufacturers quote a BER based on an alternating data pattern, which will obviously give much better BER results.

**In the interest of improvement the above specifications are subject to change without notice.**

## **2.2 APPROVALS AND LICENSING**

The SRT Series meets relevant world wide standards as outlined below, should others be required, please contact the sales office.

### **2.2.1 UK Approvals**

- MPT1329:** For UHF telemetry applications, under this specification the RF output power is limited to 500mW ERP.
- MPT1328:** For VHF product with the power limited to 10mW.
- MPT1411:** The unit is approved for use under MPT1411 where a licence is required and the output power is normally stated on the licence, the maximum power output of the ART is approximately 5Watts.
- BS2011:** The unit complies with the Vibration specification BS2011.

### **2.2.2 European Approvals**

- ETS300-220** The unit meets the specification for European licensed exempt communications with a maximum RF power level of 500mW. Please note the permitted power level may vary from country to country.
- ETS300-113** The unit meets the specification for licensed specification for data radios
- ETS300-339:** The unit meets the required CE specification and carries a CE Mark.

### **2.2.3 Other Approvals**

At the time of writing this document the product range is currently undergoing approval to the following specifications.

**U.S.A FCC Part 90 & 15**

**Canadian RSS-122/119**

**Australian AS 4268.2-1995**

# 3

## SET-UP & INTERFACING

### 3.0 SET-UP AND INTERFACE DESCRIPTION

#### 3.1 INTERNAL LINKS

The exploded view shows the main components of the radio modem; the milled enclosure, MPU control & interface board, transceiver module and LED board.

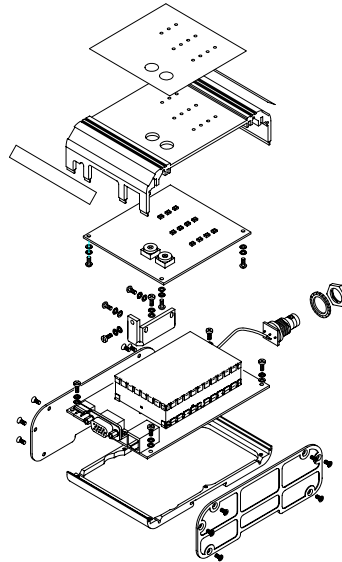

#### 3.2 FIRMWARE DOWNLOAD PORT

JP2 is a firmware download port and is used during production to download firmware into the processor's flash memory. Once programmed the 3 jumpers are installed linking 1-2, 3-4 & 5-6 for normal operation. For upgrades the links are removed and new firmware is loaded via the RS232 port.

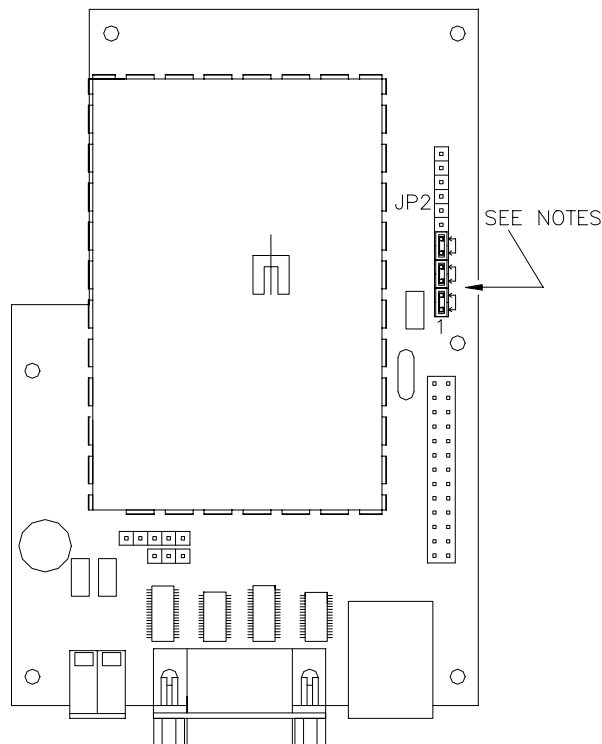

### 3.3 RS232 & 5VTTL SERIAL INTERFACE

The SRT serial port can be programmed to operate at speeds between 150 – 38400bps and is used to program the modem, control the modem during testing and for transferring data over the radio link when in operation.

Internal links can be set to provide full RS232 or 5V TTL signal levels, either mode can be run true or inverted. Unless otherwise specified the product is shipped set for “True RS232” operation. Should these parameters need to be changed, the following can be used as a guide.

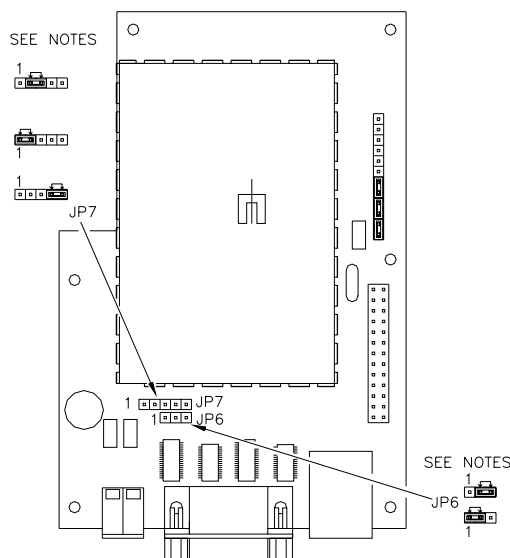

JP6 Leave open or link 2-3 for inverted signal (normal)  
Link 1-2 for non-inverted

JP7 For RS232 serial without DTR Shutdown link 2-3  
For RS232 serial with DTR Shutdown link 1-2  
For 5V TTL serial link 4-5

Note: the -5V generator for the RS232 interface is turned off if 5VTTL is selected, and also while DTR is inactive if the DTR shutdown link option is enabled. The latter option is complemented by the software DTR shutdown option which causes the processor to shut down all the radio circuits while DTR is inactive. For lowest current consumption both options must be enabled.

### 3.3.1 RS485 CONNECTION

For RS485 and RS422 an external adaptor is required, information is available from the sales office

### 3.3.2 Serial Port Pin Connections

The SRT Series is equipped with a 9 way D connector for all serial port connections, the pins of this connector are allocated as follows:

#### Pin No. Description

1. DCD: Data Carrier Detect
2. RXD: Receive Data
3. TXD: Transmit Data
4. DTR: Data Terminal Ready
5. GND: GROUND
6. DSR: Data set ready
7. RTS: Request to send
8. CTS: Clear to send
9. RI: Ring Indicate

### 3.4 12VDC POWER

A nominal 12VDC (9.6 - 15VDC) is supplied to the unit via a 2 way pluggable terminal block, the polarity is marked on the front panel and the plug has a polarity key to prevent accidental polarity reversal. In the event of a polarity reversal the circuit board is protected by diodes and fuses.

### 3.5 I2C INTERNAL & EXTERNAL BUS

The SRT Series features an I2C Bus which is used to communicate with other modules over short or medium distances. The main feature of the bus is its address mode, which will only wake up modules that are being addressed, thereby ensuring low power operation.

At the time of writing this manual a full range of analogue and digital I.O. modules are under development, a list of them is contained in the specification section, with further details available from the sales office.

#### RJ45 Connector

Pin No.	Description
1 & 2	Nominal 12VDC direct feed via a fuse & over voltage Protection
3 & 4	N/C
5	SDA I2C Data Line
6	SCK I2C Clock Line
7	I.O. Reset
8	I.O. Interrupt
9 & 10	Ground

### 3.6 SWITCHES

The two front panel BCD switches select channels, or if both are set to zero program mode is entered. When viewing an SRT with the aerial connector at the top the left hand rotary switch is the "tens" switch and the right is the "units" switch, thus to set channel 37 set the left switch to 3 and the right to 7.

### **3.7 PROGRAMMING**

Apart from the link selectable options; Firmware download and RS232/5VTTL selection, all the parameters of the SRT Series can be programmed via the serial port using either DOS or Windows based software or over the radio link via the SRT's secure "over air programming mode". The individual program can be stored on disc for future use or printed. Full details of all the programmable parameters are covered in the Programming section of this manual.

### **3.8 CHANNEL SELECTION**

The SRT Series can be PC programmed with up to 80 discrete channels. Once programmed, channels can then be selected via rotary switches on the front panel. from a PC program via the serial port or over the radio link.

### **3.9 RF POWER:**

The SRT'S are available in two power ranges: 10mW to 1Watt for ultra low power requirement, and 50mW to 5 Watts. During factory alignment testing, the DC level required for specific power levels is calculated and the curve produced is stored in ROM.

The user can then enter in any power level, the MPU will calculate and select the required power. The calibrated RF power level is PC and over air programmable directly in watts & milli-watts with an accuracy of +/-1dB.

### **3.10 INTERNAL MODEM**

The internal modem can operate at speeds between 150 and 9600 baud, at speeds up to 1200 baud FFSK signalling is used with either Bell 202 or V23 mode 2 tone sets. 2400 baud uses a 1200/2400 Hz coherent FFSK tone set, 4800 baud uses GMSK, and 9600 baud uses four level FSK with the programmable option of adding forward error correction at 9600bps.

### **3.11 FORWARD ERROR CORRECTION**

When forward error correction is switched off the radio signal employs a standard asynchronous format using a start bit, 7 or 8 data bits, odd, even or no parity, and 1 or 2 stop bits. If this format is programmed to match the serial port and runs at the same speed there is no overhead, data is transmitted over air at the same speed as it is received at the serial port. The exception to this is a radio baud setting of 9600 baud, where an extra eight synchronisation bits are sent after every 8 data bytes. For a data format of 8 bits, no parity and 1 stop bit this represents a redundancy of 9%.

Forward error correction (FEC) is a programmable option at speeds of 9600 baud. When forward error correction is switched on, the radio signal changes to a fixed format where 14 bits are used to convey every data byte. The 14 bit words comprise of 8 data bits with 5 CRC bits used to perform error correction, and one flag bit used to differentiate control and data functions in messages. An additional 14 bit frame synchronisation word is sent after every 8 data words. For a serial port data format of 8 bits no parity this represents an increased redundancy of 28% over the 9% redundancy when FEC is disabled.

The CRC used in the forward error correction system has been optimised to detect and correct errors in the modulation scheme employed by the 9600 baud encoder. It is aimed at improving performance in weak signal conditions, rather than recovering data in fades or burst error conditions. The latter requires data interleaving and packeting that can result in large frames for small amounts of data, and hence unpredictable message lengths.

The improvement in error rate when using FEC is reduced as the initial error rate gets worse. For example an initial error rate of  $1 \times 10^{-4}$  is improved by a factor of 2000 to  $5 \times 10^{-7}$ , whereas an initial error rate of  $1 \times 10^{-3}$  is only improved by a factor of 250 to  $4 \times 10^{-5}$ . In terms of receiver sensitivity the  $1 \times 10^{-6}$  error rate threshold is moved down by 0.4uV (or 6.4dBm) when FEC is switched on.

### 3.12 SQUELCH TAIL (DRIBBLE BITS) ELIMINATION

The “EDIT MODEM/INTERFACE” menu of the SRP set-up programme includes a field entitled “MESSAGE PACKETING”. If this option is turned on radio messages are framed with special control characters, if the “INTERFACE PROTOCOL” option is set to “NONE” only two characters are used, one to identify the start of the message, and one to identify the end. This allows the random characters that sometimes appear at the end of messages (called the squelch tail or dribble bits) to be eliminated. Note that once this option is enabled the radio signal is no longer compatible with other manufacturer’s systems, or with other SRT radios in which the option is disabled.

### 3.13 STATUS LED’s:

The SRT has 11 LED’s to enable the operator to see at a glance the status of the product and the serial port in operation or on test, these are:

RX	RF Carrier Detect/Busy
TX	Transmit
SYS	System
RTS	Request to Send
CTS	Clear to Send
DCD	Data Carrier Detect
RXD	Receive Data
TXD	Transmit Data
RI	Ring Indication
DSR	Data Set Ready
DTR	Data Terminal Ready

#### 3.13.1 System led

With the Exception of the System LED the remainder are self explanatory The System LED is used as a quick check as to the status of the Radio Modem and if any errors are detected it will flash out an Error number

#### 3.13.2 Error Number

The modem reports errors in two ways, firstly the BUSY led will come on and the SYS led will flash a number of times, the BUSY led will then go out again and if the fault persists the procedure will be repeated. An error number can be determined by counting the number of times the SYS led flashes while the BUSY led is on. Alternatively the error can be read by monitoring the serial port using a PC comms program running at 9600 baud, 8 data bits, 1 stop bit and no parity. An "E" is output followed by the error number. Error numbers for both modes are as follows;

<i>ERROR No</i>	<i>FAULT</i>
1	Position of the channel switches has changed.
2	A channel has been loaded that has no RX frequency programmed.
3	Transmission has been attempted on a channel that has no TX frequency programmed.
4	The receiver synthesiser phase locked loop has failed to

- lock due to bad channel data or programming of an out range frequency.
- 5 The transmitter synthesiser phase locked loop has failed to lock due to bad channel data or programming of an out range frequency.
- 6 The contents of the microprocessor's EEPROM are corrupted (failed checksum) in the general program area.
- 7 Internal comms with a high power amplifier have failed.
- 8 The contents of the microprocessor's EEPROM are corrupted (failed checksum) in the calibration area.
- 9 The contents of the microprocessor's EEPROM are corrupted (failed checksum) in the factory program area.
- 10 The programmed R.F. power setting is out of range.

### 3.14 TIME-OUT-TIMER

The time-out timer allows the maximum continuous transmission time to be set in order to prevent channel blocking due to a host fault. The timer works in all modes (external/internal modem) and is programmable in one second steps between 0 and 255 seconds. In all cases transmission will cease until the action that normally causes transmission is removed and then re-applied. More explicitly; in external modem mode the transmit enable line (DI0) must be released and then lowered again, in internal modem modes with RTC/CTS handshake enabled RTS must be dropped and then raised again, or if handshake is not enabled character transmission must be suspended for at least two character periods at the serial port baud rate. In all modes the modem's SYS led is flashed at least twice when time-out occurs, the flashing continues while lockout is in force. The lockout timer is disabled if the lockout time is set to 0. The lockout timer can be operated in "resettable" or "cumulative" mode, in resettable mode the timer restarts each time a transmission is made, in cumulative mode the timer counts up during transmit, and down during receive. If the timer counts up to the lockout time during transmit, lockout occurs; this will eventually happen if the radio spends more than half of its time transmitting. Lockout in this mode is indefinite and can only be reset by powering the radio off.

### 3.15 POWER CONSUMPTION

The SRT is a very low power product and is ideal for operation from batteries with solar power backup. The information below is intended to help the user decide on the best battery and solar cell size for operation at non powered sites.

#### 3.15.1 Transmitter RF power verses current

5Watt SRT

TX Power	5W	4W	3W	2W	1W	500mW	200mW	100mW	50mW
Max. Current	2.1A	1.8A	1.6A	1.3A	950mA	675mA	500mA	390mA	300mA

### **3.16 POWER SAVE MODE:**

The SRT is equipped with an internal and external power save mode. These are outlined below:

#### **3.16.1 INTERNAL POWER SAVE**

The internal power save facility: In this mode the microprocessor switches the transceiver off and after a pre-programmed time (Save on time) switches the unit back on (Save off time). If a carrier is not detected then the transceiver again switches off. If during the time the transceiver is awake a carrier is received, the unit will stay on. After the carrier drops out the receiver will stay on until the programmed resume time elapses. Once the resume time has elapsed the unit will return to its power save mode. The Save On/Off and Resume time are all programmable via the PC program. Obviously the amount of power saved increases with the programmed save on/off ratio, however with power save enabled long lead times must be programmed to wake up the unit before communication can take place. Therefore it may not be possible to run all applications under the power save mode due to the turn around times required by the host system. In some circumstances it is possible to achieve power save and fast polling: If polling of all outstations is carried out in cycles with a reasonable gap between each cycle, a long initial poll can be used to wake up all stations, the resume timer will then restart each time an outstation is polled allowing fast access, when the cycle is complete all stations will return to power save after the resume time has expired.

#### **3.16.2 EXTERNAL POWER SAVE**

The External power save mode: Under this mode the on/off ratio is controlled externally via the DTR line (DTR shut down must first be enabled using the set up program). In this mode more of the modem's circuits are shutdown (including the microprocessor), this saves more power but care must be taken to ensure that the modem is enabled when a transmission is to take place. Note that there is a hardware link option to allow the serial port to shut off when DTR is not active; this allows the radio current to be reduced to its bare minimum. In applications where DTR is not connected this link option must of course be disabled.

### **3.17 "RSSI" RECEIVE SIGNAL STRENGTH INDICATION**

Each ART produces an internal DC signal which is proportional to the received signal strength. The DC signal is passed to the internal MPU where it accurately measures its value by an internal A-D converter. The proportional DC voltage is individually calibrated against a signal generator in production and levels are mathematically calculated for accurate measurement in the field. The signal strength can then be read in dB micro volts on a PC connected to the serial port.

# 4

## MODES OF OPERATION & PROTOCOLS

## **4.0 DIGITAL MODES OF OPERATION & PROTOCOLS**

This section serves as a guide to the various ways the SRT Series can transfer digital information via its serial port in point to point links, point to multi-point (scanning telemetry) systems and networks employing store and forward repeater nodes.

Due to the exceptionally large flash memory space available within the SRT, we are able to support various PC selectable modes of operation to suit many different applications.

At the time of writing this manual, Transparent mode, Hayes "AT" and MODBUS and RFT Routing Modes are supported, with DNP3, IEC870 and MX25 modes under development. The basic modes of operation of the radio modem are outlined below.

### **4.1 SERIAL INTERFACE & TRANSMISSION**

The serial interface can be programmed either to use RTS/CTS handshaking to initiate transmission, or to transmit whenever data is present at the serial input. In the latter mode CTS is still operated to implement flow control but can be ignored unless message sizes exceed 1k byte and the serial port baud rate is higher than the radio signal baud rate. These handshaking modes are compatible with the old Communique CMD400 modes A, C and D. Mode B (byte stuffing mode) is not supported.

#### **4.1.1 TRANSMISSION USING RTS/CTS HANDSHAKING**

If handshaking is enabled transmission is started by operating RTS, CTS can then be monitored for flow control purposes. In the idle state CTS is inactive, when RTS is operated CTS will become active immediately and data may be input to the serial port, when all data has been loaded to the serial port RTS should be dropped, transmission will continue until all data in the serial input buffer has been sent, then CTS will become inactive and transmission will cease. During transmission the amount of data in the serial buffer is checked by the radio, if the buffer becomes  $\frac{3}{4}$  full CTS is dropped to request the host to stop loading data, CTS is activated again when the buffer is reduced to  $\frac{1}{4}$  full. To prevent timing problems data will still be accepted into the buffer when CTS is de-activated due to buffer filling during transmit, however any data received once CTS has dropped at the end of a transmission will be discarded, this prevents such data from being prefixed to the beginning of the next message.

#### **4.1.2 TRANSMISSION WITHOUT HARDWARE HANDSHAKE**

If RTS/CTS handshaking is disabled the radio will start transmission as soon as data is received at the serial port, transmission ceases as soon as the serial buffer has been emptied and a period equivalent to two characters at the radio signal baud rate has elapsed. It is important to note that since transmission ceases as soon as a two character delay in the incoming data stream is seen, data characters in a message must be presented in a continuous back to back stream.

In this mode CTS is still used to indicate the serial buffer fill level in the same way as described in the section on transmission using handshake, the difference is that in the idle state CTS is always active indicating readiness to accept data. In most applications CTS can be ignored as messages are likely to be smaller than the serial input buffer (1k byte), bear in mind also that if the radio baud rate and data format is the same as that configured for the serial port the buffer is being emptied as fast as it is being filled and so buffer overrun is unlikely.

#### **4.1.3 DATA RECEPTION**

Any data received by the radio is simply output to the serial port, the DCD line can be programmed to operate in three different modes to assist the host. Firstly by indicating that a carrier is detected on the radio channel, this is useful if a busy lockout function is required (although this can be dangerous if the channel is susceptible to interference as well as wanted signals), secondly DCD can indicate presence of a carrier and a valid data signal, data will normally be output under this circumstance, the third mode behaves in the same way as the second except that DCD remains active until all data has been output to the serial port after the signal has gone, this allows DCD to be used as a wake up signal.

#### 4.2 TRANSMIT & RECEIVE TIMING

The SRT only operates in a simplex or semi-duplex mode. In simplex mode the receive and transmit frequencies are the same, where as in the semi-duplex mode they are different.

In either mode data is only sent in one direction at a time as the radios do not have separate synthesisers for transmit and receive. If full duplex mode is required (transmit & receive at the same time) the ART product should be considered.

In simplex/semi-duplex mode, the radio synthesiser must be reloaded each time Receive or Transmit is selected. Although relatively small the synthesiser loading time must be taken into account when looking at data transfer times.

In order to reduce adjacent channel interference in line with ETS300-113, the power output from the transmitter has finite rise and fall times, a distant receiving radio will therefore see an incoming signal later than a nearby one. The receiving radio also requires time for the carrier detect circuit to operate and for the modem to lock on to the incoming audio signal.

When using the SRT, there are a few timing considerations, the main one is the programmable "lead in delay", this time is required for the modem to lock on to the incoming data stream and this is dependant on the radio signal baud rate. Minimum timings are given below:

Baud Rate	Lead in Delay
150	80ms
300	60ms
600	40ms
1200	40ms
2400	40ms
4800	20ms
9600	30ms

For simplex/semi-duplex operation, time is required for the transmit and receiver synthesiser to be loaded and locked prior to transmission/reception. This timing constraint is important when deciding how soon after receiving a message a reply may be sent. For simplex/semi-duplex operation the SRT is ready to receive data approximately 25ms after transmission ceases. It is therefore necessary to either wait this length of time after receiving a message before sending a reply or to extend the lead in delay by the same amount to hold off transmission of the data.

For applications where power save is in use the lead in delay should be extended to allow the receiving device to wake up. The time required can be calculated by adding the save on time to the save off time and adding 10 percent, e.g. for a save on time setting of 800ms and a save off time of 200ms the lead in delay should be 1100ms.

Care must be taken when replying to a previously transmitting SRT when RTS/CTS handshake is not being used, in this mode the transmitting device will wait for two character times before turning off its carrier and may therefore miss the beginning of a reply if it comes too soon, this may be overcome either by imposing an additional two character delay in the controlling device or by extending the lead in delay by that amount.

The ART also has a facility for imposing a lead out delay, this is the time that the carrier remains on after transmission of the message is complete, this delay can normally be left at zero, it is only of use where a controller makes use of the DCD signal to suppress data processing but suffers some delay in processing received data.

#### 4.2.1 RECEIVE TO TRANSMIT SWITCHING TIME

When using the internal modem the action that initiates transmission can be either receipt of a character at the serial port or the operation of RTS. These examples use the first mode. The radio does nothing until the stop bit of the first character for transmission has been received, the transmitter is then started:

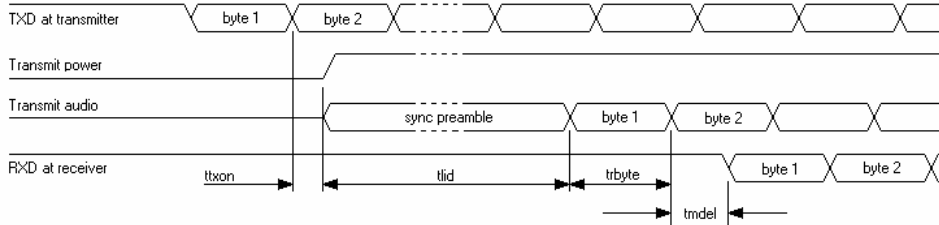

The time delay between receipt of the stop bit for the first character to be transmitted at the transmitting radio and output of the start bit of that character at the receiving radio is the sum of the values ttxon, tlid, trbyte, and tmdel shown in the diagram above. Values for these parameters are indicated below:

**TABLE A:** Timing values for duplex and simplex modes are as follows:

symbol	Description	Semi-duplex	simplex
ttxon	Time from external action to commencing transmission	9ms	9ms
tlid	Duration of synchronisation transmission (lead in delay)	Table B	Table B
trbyte	Duration of 1 byte at radio signal baud rate	Table C	Table C
tmdel	Modem decode latency	Table D	Table D

**TABLE B:** The lead in delay is a programmable parameter but minimum values dependant on baud rate must be adhered to. However, in a scanning system with the base station on continuous transmit the base station lead in delay can be set for Zero (thereby saving valuable time) as the internal outstation modems will always be synchronised.

Baud	150	300	600	1200	2400	4800	9600
Min tlid	80ms	60ms	40ms	40ms	40ms	20ms	30ms

**TABLE C:** The duration of a byte at the radio baud rate is dependant upon the data format employed, the table below assumes a format of one start bit, 8 data bits, no parity and 1 stop bit, i.e. a total of 10 bits per character. If another format is used the appropriate correction must be made.

Baud	150	300	600	1200	2400	4800	9600
trbyte	66.7ms	33.3ms	16.7ms	8.3ms	4.17ms	2.08ms	1.04ms

**TABLE D:** The modem decode latency takes into account delays introduced by hardware and software filters. The total delay is baud rate dependant:

Baud	150	300	600	1200	2400	4800	9600
tmdel	6.9ms	3.5ms	1.7ms	1.3ms	1ms	1ms	1ms

#### 4.2.2 MESSAGE DURATION

The time taken to transmit a message can be simply derived by multiplying the number of characters in a message by the values given in table C making any appropriate corrections for data format. The exception is 9600 baud where extra synchronisation sent during the message must be taken into account, 8 synchronisation bits lasting a total of 0.833ms are sent after every eighth message character.

#### 4.2.3 TRANSMIT TO RECEIVE SWITCHING TIME

In full or semi-duplex operation transmit to receive switching time does not need to be considered as the receive path is maintained during a transmission, in simplex operation some time must be allowed to reload the transmitter synthesiser to stop it from interfering with the receiver. The diagram below indicates the minimum time in which the radio is able to receive a signal after completing a transmission.

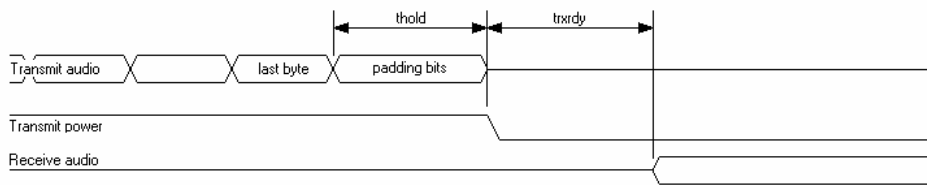

symbol	Description	value
thold	Period for which carrier is held up after sending last data byte	2.5ms + LOD
trxdy	Time to reload transmit synthesiser in simplex mode	6ms

During the time thold the radio transmits some padding bits to allow for propagation delays in the receiving device before shutting off the carrier, this prevents possible chopping of the message tail. The time thold is composed of a fixed 2.5ms period plus the programmable value LOD (lead out delay). LOD is normally set to zero. After the time trxdy has expired the radio is ready to receive a new signal.

N.B. If RTS/CTS handshaking is not used the transmitter is turned on whenever data is received at the serial port, the transmitter is left on until all buffered data has been transmitted and no data has been input for a time equivalent to the length of two characters at the radio baud rate (refer to table C). In general data transmitted by the radio is delayed with respect to its receipt at the serial port by the receive to transmit switching time, if the radio baud rate and serial port baud rate and both data formats are the same this delay remains constant throughout the transmission. At the higher baud rates this delay is generally greater than the length of two characters and so the procedure to stop transmission is started as soon as the last character has been sent, at the lower baud rates however it is possible that the time thold is extended while the radio waits for the two character timeout to expire, this can also happen if data characters are not loaded back to back into the serial port.

#### 4.3 RADIO DATA FORMATS

The radio signal can be set up to operate using 7 or 8 bit data, 1 or 2 stop bits, and odd, even or no parity. This setting is independent of the serial port setup. This allows compatibility with other radios. The Communique CMD400 does not set these parameters independently, with one exception the radio signal format in this radio is set to be the same as that of the serial port even though the baud rates can be different. The exception is mode C where the radio signal format did not include parity, if compatibility with this radio is required parity must be disabled in the radio signal regardless of the serial port configuration. Later versions of the CMD400 had an additional mode entitled "mode C plus parity" in which parity was included, use of this mode did not give rise to the exception.

#### **4.3.1 SYNCHRONOUS/ASYNCHRONOUS TRANSMISSION FORMAT**

The radio signal format can be programmed for asynchronous or synchronous operation at baud rates up to 1200. At baud rates of 2400 or more operation may only be synchronous.

In synchronous mode inverted NRZI encoding is used where a one is represented by a transition in the binary data, every transmitted bit fits into a time slot defined by the baud rate, this allows a phase locked loop to lock on to the data stream to give better performance in noisy conditions, the inverted NRZI encoding allows this to continue even when the signal is idling sending stop bits. The inverted NRZI encoding gives a further advantage with GMSK signalling since the polarity of the signal is unimportant.

In asynchronous mode NRZ encoding is used where a “one” tone represents a binary one, and a “zero” tone a binary zero, whilst each character consists of bits of equal duration defined by the baud rate, the time between the end of a stop bit and a following start bit may be arbitrary. This prevents the implementation of a phase locked loop to improve signal to noise performance but does allow use within older systems that do not implement synchronous transmission or NRZI encoding.

### **4.4 OPERATING MODES**

#### **4.4.1 TRANSPARENT MODE**

The radio has no knowledge of the data it is transmitting, data is simply transmitted and received under hardware control with the option of RTS control or initiation of transmit after receiving serial data, with CTS providing an optional flow control. This configuration is useful when expanding older systems where the radios must be compatible with others of various manufacturers.

#### **4.4.2 PROTOCOL SPECIFIC MODE**

The radio recognises a complete frame and only transmits and receives data conforming to that format. No addressing of radios or routing of data is performed. Protocols such as MODBUS & DNP3 can be supported in this way.

#### **4.4.3 ROUTING MODE**

The radios recognise a protocol specific frame and the address to which the frame is to be sent. Routing information must be stored in each radio for each destination address that requires the use of repeaters or store & forward nodes. Any radio in the system can operate as a repeater/store & forward node. The radio does not perform any acknowledgement or retries. Any protocol using a fixed address field such as MODBUS, RFT ROUTING can be supported.

#### **4.4.4 DIAL UP MODE**

Hayes protocol is used to dial up the radio link which may include routing via repeaters or store & forward stations; the route information is not stored but is passed in the dial up command in the form of a telephone number, once the link is established it is transparent and so independent of the protocol being transported. This allows point to point protocols such as SLIP and PPP (and hence TCP/IP) to be conveyed. Dial up is less efficient for small data transactions because of the data exchanges carried out during the connect and disconnect phases.

## 4.5 STORE & FORWARD

Store & Forward forms the basis for a routing network, where messages can start from any point in the systems, such a system is often known as “reporting by exception”, where a change in parameters at a location (Node) is detected and the change is sent to the monitoring centre via preset or dynamic routing.

In its simplest form a Store and Forward (S&F) node can be used to extend the range of a point to point or point to multi-points with an SRT acting as a store & forward or repeater node. The SRT series supports up to six repeaters within one link, although the more repeaters used the greater the starting signal strength has to be, as there will be some accumulative degradation over the whole link.

The incoming message is received by the S&F node and the address is checked against a list held in the S&F node’s memory. If the address on the incoming message matches one on the SRT’s internal routing list, the MPU will key up the transmitter and pass the message on.

In a relatively simple S&F forward operation with only one repeater stage the address can be the final destination address. So for a signal to go from A> C via repeater B, the address header would be C. Repeater B would start to receive the message from A and would check the address C against the stored routing table. If it finds a match, the transmitter will pass on the message.

In a more complex system with multiple repeaters, A> B> C> D the address can again be the final destination D and first repeater B will check the address and forward it on to the 2<sup>nd</sup> repeater C which will in turn pass it on to D and so on. This is different from the Hays mode where the address route is in the message.

Depending on the application & software, all or some of the messages may be forwarded.

The longer the message and the slower the transmitter rise time the longer the delay. If duplex ARTs are used as repeaters, re-transmission can start as soon as the address is checked long before the incoming message has been decoded, thereby saving valuable time.

For simple systems this method can produce a satisfactory solution as all the data the repeater receives will either be for the local site via the RS232 port or for onward transmission.

## 4.6 STORE & FORWARD BASED ON A CLIENTS PROTOCOL.

A Store and Forward configuration can re-transmit all traffic it receives and in some applications, where there may be only one repeater serving many outstations, this may be required. However, to conserve valuable air time and avoid the possibility of collisions due to coverage overlaps with other repeaters transmitting at the same time, normally only messages that require forwarding by specific repeaters are re-transmitted.

This is achieved by stripping out the addresses of incoming messages, comparing the address with the list of outstation addresses stored in the unit and only forwarding on those that match. However, this format requires knowledge of the client’s message structure and where the address in the message can be found.

The other option is to route messages via the addresses embedded in the radios, using the AT Network mode. In either option there is normally local communication at the store and forward site, via the RS232 port.

We have written various store & forward drivers to cope with a number of client specific message formats and are always happy to write new drivers as and when required, Further information is available from the sales office.

## 4.7 HAYES AT MODE

The ART series radios can be programmed to run a Hayes AT command set that allows dial up networking on a radio system with support for low power operation. Any radios in the system can be used as relays, and as routes are defined in the dial up command there is no need to store routing tables in the radios themselves. Remote programming is also enabled whenever Hayes At mode is enabled.

When “HAYES AT” mode is enabled in the “EDIT MODEM/INTERFACE” menu of the setup

programme the "NETWORK ID" and "RADIO ADDRESS" fields must be filled out such that every radio in a system has the same network id, but a different radio address. Notes should be kept detailing the installation of radios and their addresses. It is also possible to set addresses by accessing the Hayes type "S" registers from the host equipment; this allows all radios to have the same setup and so to be interchangeable in the field.

#### 4.7.1 AT COMMAND SUMMARY

Commands are not case sensitive, when entered from a keyboard the backspace key may be used to delete errors. Every command except the escape code (default +++ ) must begin with the AT prefix and be terminated with a carriage return. The maximum command line length is 40 characters. More than one command may be entered on a line and spaces may be entered between commands, only the first command on a line should be prefixed by "AT".

The following commands are supported, brackets indicate an optional parameter or character, the S registers referred to are used to store parameters relevant to this mode of operation, they may be also accessed using the PC setup programme:

AT Attention. Required command prefix, except with the escape code (default +++), use alone to test for the OK result code.

D (rrr,rrr...)ddd Dial. The optional relay addresses (rrr) and the destination address (ddd) should be entered as three digit decimal values in the range 001 to 255. Relay addresses must be entered in the order they will be encountered with the first relay address appearing immediately after the D character. Once entered the radio will attempt to establish a link through the relays with the destination.

For example;

ATD003 Dial out directly to radio number 3

ATD001002003 Dial out to radio number 3, using radios 1 and 2 as relays.

N.B. there are two special functions of the dial up command, these are effected by preceding the route with 8 or 9, both of these functions are used by diagnostics software and should not be used by the application.

O Switch from command mode to transparent mode. Once transparent mode is entered no more AT commands will be interpreted, transparent mode is terminated with the escape code.

H Hang up. The hang up command disconnects a link and should be issued to the radio through which the link was originally established using the dial command. If transparent mode has been entered the escape code must first be issued to return to command mode. Note that a faster disconnect is possible using the DTR hardware handshake line.

&V View the settings of all of the S registers and also the error code reporting mode. The values in the S registers are loaded from Eeprom on power up or following a reset command, they may be subsequently modified using other commands, issuing "AT&V" views the active values held in volatile memory, not those stored in Eeprom.

&W Write the active S register values to Eeprom. This causes the S register values to be preserved following loss of power or a reset.

Z	Software reset. The radio is re-initialised and the S registers are overwritten with the values stored in Eeprom.
Sr?	Display the value of S register r. For example issuing "ATS23?" displays the value of S register 23. The value r can be in the range 0 to 31.
Sr=n	Sets the value of S register r to the decimal value n. For example issuing the command "ATS23=34" sets S register 23 to 34 decimal. The value n may be in the range 0 to 255. The value r may be in the range 0 to 31, however not all locations are used, and some are read only. Attempting to write to an S register that is not used or that is read only causes the error result code to be returned.
V(n)	Sets verbal or numeric result codes. Result codes are returned for most AT commands and can be numeric (suitable for automated operation) or verbal (suited for keyboard operation), the value of n determines the mode, if 0 numeric mode is set, if 1 verbal mode is set, omission of the value n causes numeric mode to be set. For example issuing ATV1 sets verbal mode. Note that storing the active configuration using the AT&W command does not store verbal/numeric mode, verbal mode is always restored at power up or reset.
Q(n)	Enables/disables result codes according to the value n. A value of 0 enables codes, a value of 1 disables them, omission of n enables codes. Note that storing the active configuration using the AT&W command does not store this status, codes are always enabled at power up or reset.
I(0)	Information. The zero suffix may be omitted. This command returns a text string giving information about the radio and its firmware version.

An example text exchange is given below:

TEXT SENT	TEXT RECEIVED	
ATS23=2 V Q	OK	The radio address is set to 2, verbal result codes are enabled.
ATD005004	NO ANSWER 005	A dial out to radio 4 via radio 5 was attempted but radio 5 did not respond.
ATD006004	CONNECT	A dial out to radio 4 via radio 6 was attempted and the connection was successful.
ATO		Transparent mode was entered, no result code is returned for this command.
Hello Fred	Hello Bill	Fred and Bill exchange data. This data can be text or binary information, the link is transparent to all except the escape code.
+++		The escape code was entered, no response is given to the code.

ATH	OK	The link was disconnected.
ABC	ERROR	The command was not understood as it is not valid.

#### 4.7.2 SERIAL PORT HANDSHAKING WITH HAYES AT MODE

The DTR, DSR, DCD,CTS and RI lines are all used in Hayes mode, RTS can also be used as an option. DTR is used to tell the radio that the connected host is awake and is a command to the radio to exit power save mode (if enabled), DSR provides confirmation of this action to the host. DCD is used to indicate to the host that a link has been set up and that a transparent connection to the other end exists. CTS is used to provide flow control, RI indicates an incoming call, it may be used as an outstation wake up signal. RTS can optionally be used to hold the transmitter on while a message is loaded, this is required to prevent messages being broken up if delays occur in serial input, this can cause loss of parts of messages if relays are used.

#### 4.7.3 POWER SAVING

The radio can be operated with or without power save enabled, typical applications might utilise power save for some outstation radios, whilst relay stations would operate without power save, this minimises call set up times. The power save duty cycle can be modified to provide the best optimum between call set up time and power saving.

The power save period is set in the main edit menu of the set up programme under the heading "PSAVE ON TIME". To enable power save the "RADIO ADDRESS" must be greater than or equal to "MIN PWR SAVE ADDRESS" and less than or equal to "MAX PWR SAVE ADDRESS". This scheme is used so that a radio knows whether it has to issue "wake up" calls when dialling another radio.

As an example setting "PSAVE ON TIME" to 5 seconds causes the radio to power down for 5 seconds, the receiver is then switched on and a check is made for the presence of a radio carrier, if none is seen the radio powers down again. If a carrier is detected the radio waits for a period long enough to identify an incoming "wake up" signal, this period is calculated by the radio according to the programmed radio signal baud rate. If no wake up call is seen the radio powers down again, if so the radio stays awake allowing a link to be established, it returns to the cyclic power save mode when the link is cleared down.

Note that if "DTR SHUTDOWN" is enabled a radio remains completely shut down while DTR is inactive, it will not wake up according to the power save timer to see if any incoming messages are present. This mode should therefore only be used in conjunction with real time message scheduling.

#### 4.7.4 PROGRAMMING PRECAUTION

When the master station or relay radios send an outward bound message, the address of the radio to which the message is being sent is checked against the min and max power save addresses, if a power saved radio is indicated a cyclic wake up message is sent for the period indicated by the programmed power save on time. If a power saved radio is not indicated a quick wake up message is sent immediately. These parameters along with some others are also used to calculate a timeout time in the event that no reply is received. *It is therefore essential that all radios in a system are programmed with the same parameters even if not power saved, otherwise communications will fail.*

#### 4.7.5 CALL SET UP PROCEDURE

Any radio in the network may be asked by its host to set up a data link to another radio, this link may involve forwarding through intermediate radios. The radio must then set up that link and inform the host of success or failure, if successful the radio can then be asked to enter a transparent mode where data applied is simply passed across the network to and from the

final destination. Transparent mode will then be terminated by the host and the radio will then terminate the link.

A radio will spend most of its time idling, if power save is enabled its processor will be shut down conserving power, the host can wake up the radio by asserting DTR, when awake the radio will respond by asserting DSR. The radio will now be in a control mode where it can respond to Hayes AT commands to set up a link, once the link is established the host is informed by the returned AT error code that it may ask the radio to enter transparent mode, when this is done DCD is raised and the host may communicate over the network. When it has finished it may terminate transparent mode either by using the AT escape code and then asking the radio to hang the link, or by dropping DTR, the radio will then inform other elements of the link that the transaction is complete, and drop DCD. If DTR is not active the radio will then return to sleep. If the link fails in transparent mode the radio must inform its host, since it is in transparent mode it can only do this by dropping DCD. The host should then terminate in the usual manner, and if necessary attempt the procedure again.

If "RTS/CTS HANDSHAKE" is enabled RTS is only needed during transparent mode, the transmitter will be keyed as long as RTS is asserted and message data can be loaded, CTS provides flow control. RTS/CTS operation in this mode is identical to that when no interface protocol is selected. It is not necessary to operate RTS in command mode when issuing AT commands.

If a radio receives a request to set up a link with itself as the destination it will raise RI to wake up its host, if auto answer is disabled ("AUTO ANSWER TIME"=0), it will wait for the "HOST INACTIVITY TIME" for the host to accept the call by raising DTR and issuing an ATO command, DSR will be raised in immediate response to DTR. If auto answer is enabled the radio will wait for the number of seconds programmed as the "AUTO ANSWER TIME", it will then enter transparent mode automatically but only if DTR has been raised. In either scenario DCD is raised as soon as transparent mode is entered and the calling radio is informed that the link is valid. The link will normally be terminated by the calling party, the radio will inform its host that this has happened by dropping DCD, the host should then use the AT escape code to terminate transparent mode or drop DTR. If DTR is not active DSR will be dropped and the radio will return to sleep.

Note that if DTR is dropped before a dial up command has been completed the link members will be left in an undefined state waiting to time out. Also if the dialling radio is power saved it will return to sleep before completing transmission of the AT error code to the host resulting in corrupt serial data. It is therefore recommended that DTR should not be dropped until commands have been completed and the appropriate error codes returned.

The operation of the hardware handshakes lines can be summarised as follows:

DTR when raised is a signal to the radio to wake up and enter command mode. Dropping DTR cancels all operations and returns the radio to idle.

DSR when raised provides acknowledgement that the radio is awake, or when dropped that the radio is entering idle.

DCD when raised is an indication that a link has been established and that transparent mode is active, it is dropped when the link fails or is terminated.

RI when raised is an indication that an incoming call is being received.

CTS indicates that there is space in the serial input buffer.

RTS is optionally used to key the transmitter in transparent mode.

#### 4.7.6 RADIO ROUTING

Routing is determined by the dial up command used by the calling host. Radios will pass on route information to all members of a link at the point of call set up. When a radio calls another radio either because its host has requested a dial up or because it has been told by another radio that it is to be part of a link, it first sends a wake up request to the next radio in the route and waits for a reply, when this is received the route information is sent, no reply is required to this message, the next message expected is a link fail or link established message originating from the final destination radio. When received the link established message is forwarded on to the original calling radio. If a radio fails to respond to the wake up signal the radio calling it will return the address of the failed radio in the link fail message, a final destination radio may also reply with a message indicating that the destination host did not respond to the wake up procedure. This data is returned to the host by appending the "NO ANSWER" error message with the failed address in ASCII numerals or the message "NO PICK UP". If no link failed/established message is received "NO ANSWER" is returned on its own.

#### 4.7.7 IMPLEMENTED S REGISTERS

The S register values can also be programmed using the A4P setup programme, the implemented registers are listed by function in the "EDIT MODEM/INTERFACE" menu.

S0                    AUTO ANSWER

Sets the number of seconds to wait after raising RI before entering transparent mode or if zero waits for the host to respond with an ATO command (up to the time set by S21).

S1                    not implemented

S2                    ESCAPE CHARACTER

Sets the value used for the 3 character escape code.

S3 to S11            not implemented

S12                    GUARD TIME

Sets the time in 20ms units required to separate the escape code sequence from other data.

S13                    NETWORK ID LSB

S14                    NETWORK ID MSB

Both bytes are transmitted and checked as part of every radio message.

S15                    MIN POWER SAVE ADDRESS

S16                    MAX POWER SAVED ADDRESS

All radios within the range max to min inclusive will operate in power saved mode. Any comms with destination addresses in this range will start with a long wake up message.

S17                    RADIO SIGNAL BAUD AND FORMAT (read only register)

Bit 0-2    baud rate (0=150, 2=600, ... 6=9600)

Bit 3      1=Asynchronous mode, 0=Synchronous mode

Bit 4      1=Parity Enabled

Bit 5      1=Odd parity, 0=Even Parity

Bit 6 1=7 bit data, 0=8 bit data  
Bit 7 1=2 stop bits, 0=1 stop bit

This register is read by some of the diagnostic programmes available in order to determine message times and hence timeouts.

S18 HOST INACTIVITY TIME

The time for which a radio will wait for its host to wake up after raising RI if auto answer is disabled.

S19 to S22 not implemented

S23 RADIO ADDRESS

S24 to S31 not implemented

## 4.8 MODBUS

### 4.8.1 SETTING UP MODBUS OPERATION

The ART series can be programmed to transport "MODBUS ASCII" or "MODBUS RTU" format messages in single master systems. These options are selected as the "INTERFACE PROTOCOL" in the "EDIT MODE/INTERFACE" menu. It is not necessary for all radios to run the same Modbus interface, "MODBUS ASCII" and "MODBUS RTU" modes can be mixed within a system. Remote programming is always enabled when either Modbus interface is enabled.

When Modbus modes are enabled the "NETWORK ID" and "RADIO ADDRESS" fields must be filled out such that every radio in a system has the same network id, but a different radio address. Notes should be kept detailing the installation of radios and their addresses.

When transporting Modbus messages the master station radio must be programmed with a routing table, this is also accessed in the "EDIT MODEM/INTERFACE" menu by setting "ROUTING TABLE" to "ON" and selecting "EDIT ROUTING TABLE". This selection leads to several pages of Modbus addresses, the route by which every Modbus address is reached must then be entered, for example if the Modbus device with address 37 is physically connected to the radio with radio address 23, and radio 23 is accessed from the base station via relay radios 4 and 19, then the field entitled "MBUS 37" should be loaded with the route "4,19,23". If the Modbus devices with Modbus addresses 65 and 93 are physically connected to radio 45 and no relays are required then the fields entitled "MBUS 65" and "MBUS 93" should both be loaded with "45".

If no routing table is loaded or a Modbus address cannot be found in the routing table the radio assumes that the destination radio address is the same as the Modbus address and that no relays are required. This can be taken advantage of in simple schemes where no more than one Modbus device is connected to any one radio.

### 4.8.2 MODBUS OPERATION

Operation in Modbus modes relies on the master/slave poll/reply nature of Modbus. The set up of the radios does not differentiate between a master and slave, the only difference in practice would be that the master station radio will be loaded with a routing table. There is no restriction on the number of masters in a system, but they should all be loaded with routing tables.

When a poll is initiated at a master station radio the destination Modbus address in the Modbus message is looked up in the routing table to determine the addresses of the radio(s) required to complete the link, the message is then sent and all the radios expect to send a reply back the same way. Once this reply has been sent the radios are all ready to start another poll/reply sequence.

If a radio is specified as a relay in a link any connected Modbus devices will not be aware of comms that take place as no activity occurs on the serial port in this state. This may cause problems however if more than one master exists in a system as a radio that is being used as a link in a relay is not available to transmit messages.

#### **4.8.3 POWER SAVE OPERATION WITH MODBUS**

When Modbus modes are enabled in the A4P programme two further fields appear entitled "MIN PWR SAVE ADDRESS" and "MAX PWR SAVE ADDRESS", if power save operation is not required set both these fields to zero.

If power save operation is required it is enabled by setting the "RADIO ADDRESS" to a value greater or equal to "MIN PWR SAVE ADDRESS" and less than or equal to "MAX PWR SAVE ADDRESS". The radio will then enter low power standby mode for the time programmed in the "PSAVE ON TIME" field in the main edit menu, it will then wake up and check for an incoming signal, if none is present it will return to sleep and repeat the cycle. If a signal is detected the radio will stay awake until a reply to the outward bound message has been returned.

When the master station or relay radios send an outward bound message, the address of the radio to which the message is being sent is checked against the min and max power save addresses, if a power saved radio is indicated a cyclic wake up message is sent for the period indicated by the programmed power save on time before the actual data message is sent, if a power saved radio is not indicated the data message is sent immediately. These parameters along with some others are also used to calculate a timeout time in the event that no reply is received. It is therefore essential that all radios in a system are programmed with the same parameters even if not power saved, otherwise communications will fail.

Note that if "DTR SHUTDOWN" is enabled a radio remains completely shut down while DTR is inactive, it will not wake up according to the power save timer to see if any incoming messages are present. This mode should therefore only be used in conjunction with real time message scheduling.

#### **4.8.4 SERIAL PORT HANDSHAKING WITH MODBUS**

When Modbus modes are enabled the RS232 port lines DTR, DSR and RI, can be used to assist in power saving the host Modbus device. The RTS and CTS lines are not used and the "RTS/CTS HANDSHAKE" option in the "EDIT MODEM/INTERFACE" menu of the A4P programme should be set to "OFF". The RI (ring indicator) line is asserted when a radio detects an incoming message, it can be used to wake up a Modbus slave device, when the Modbus slave is ready to accept data it should assert DTR, DSR will be asserted in response and the received message will be output to the Modbus device. The "HOST INACTIVITY TIME" field in the set up programme defines a time limit for the Modbus device to assert DTR in response to RI, if this time limit is exceeded RI is dropped and the radio sends back a reply indicating the destination device failed to respond and the link is cancelled. This time is also used to define the time limit for the Modbus device to reply to the incoming message, if the time limit is not exceeded the reply is sent back to the master station and RI is dropped.

The Modbus slave may then release DTR and return to power save mode. Note that as long as DTR is asserted the radio will not return to its power save mode (if enabled in the setup programme). DSR will remain asserted in this case.

The master station can also control the power saving of its radio using DTR, the radio will operate in power save mode as long as DTR is not active, asserting DTR wakes the radio, DSR is asserted in return to indicate that the radio is awake and ready to accept data.

If use of the handshake lines is not required DTR should be connected either to a voltage of +3.5 to +15V such that sleep mode is never allowed or at slave sites it can be connected to RI so that the radio stays awake as long as RI is asserted.

#### **4.8.5 TIMEOUTS IN MODBUS MODES**

When a transmission from a master station radio is made in Modbus mode the radio will calculate a timeout for a reply, this calculation is based on many configuration parameters including the radio baud rate, lead in delay, host inactivity time, maximum message length, power save timing etc. If power saving is enabled and the baud rate is low this time can be large (the calculation limits the result to a maximum of 4.25 minutes. To reduce the possibility of "hung" radios the destination radio will send a link closing message if the destination Modbus slave does not reply. This link closing message is only used by the radios to close the link, it is not passed to the Modbus master.

If the Modbus master itself times out before the radio link does, it can send another poll, radios along the link will cancel the previous route and set up the new one. The exception to this is the previous destination radio if it is still trying to wake up its Modbus slave, it will ignore the new message and try to download its original message when the slave awakes, a conflict will then arise if a reply is sent. To avoid this situation the Modbus master timeout time should allow the maximum "HOST INACTIVITY TIME" to expire plus the time required to get a message and its reply through the link.

## **4.9 RFT ROUTING PROTOCOL**

### **4.9.1 SETTING UP RFT ROUTING OPERATION**

The ART series can be programmed to route non-specific protocol messages in single master systems using "RFT ROUTING" mode. This mode supports relay messaging. This option is selected as the "INTERFACE PROTOCOL" in the "EDIT MODEM/INTERFACE" menu. Remote programming is always enabled when this mode is enabled.

In describing operation the address contained in the host system message will be referred to as the "protocol address" and address programmed in the radio under the "RADIO ADDRESS" field in the setup program will be referred to as the "radio address".

RFT Routing mode is controlled at the master station by picking out an 8 bit protocol address field in the message to be sent, this address is then looked up in the routing table stored in the master station radio. The routing table can contain the radio address (as programmed in the RADIO ADDRESS field in the setup program) of a single radio connected to the required destination device or a list of relay radio addresses plus the destination radio address. The message is then transmitted from the base station radio as a packet with the routing information prefixed to it. The message is then relayed through any relay radios specified until it reaches the destination radio where it is output from the serial port in its original form with the packet information removed. During this process each radio considers itself to be part of an established link. A reply is then expected, however the outstation radios are not programmed with routing tables, a reply issued is assumed to be destined to the master station. The address in the protocol message is therefore not checked and the reply is simply

sent back down the established link to the master station radio where it is output from the serial port. As the reply is passed back the link members no longer consider themselves to be part of an established link and return to idle.

Note that there is no differentiation in operating mode between a relay radio and an outstation radio, if an outstation radio is specified as a relay in a link any device connected to the serial port will be unaware of relay communications taking place.

The packet used to transfer protocol messages specifies the route to be taken and also the current stage in the route, it is therefore of no concern if radios further down a relay link "hear" the message before they are expected to repeat it, they will ignore the message until specifically requested to repeat it.

The position of the address in the protocol field is specified using the "ADDRESS OFFSET" parameter in the setup programme. A setting of 0 specifies zero offset, i.e. the address is the first byte in the message, an offset of 6 specifies the 7<sup>th</sup> message byte and so on. 16 bit addressing or more is not supported as a maximum of only 256 destinations can be supported by the routing table. If the protocol message format does use 16 bit addressing specify the offset for the least significant byte and try to ensure that no two devices use the same l.s.b. in their address.

In order to determine the position of the address in a protocol message the radio has to know where the message starts and ends, this can be done in one of two ways: If the RTS/CTS HANDSHAKE option is turned on RTS should be activated before commencing a message, CTS will be activated in response and the message may be loaded, the first character received after CTS becomes active is considered to be the start of the message. Transmission will start as soon as enough characters have been loaded for the protocol address to be extracted and the route determined from the routing table. Transmission continues until RTS is deactivated, CTS will drop when transmission is complete. CTS may also drop if the serial input buffer becomes more than  $\frac{3}{4}$  full to implement flow control, if this happens RTS should be kept active until CTS is re-activated, more characters may then be loaded or RTS may be dropped.

If the RTS/CTS HANDSHAKE option is turned off, the radio relies on gaps in the serial data to determine the start and end of messages. A gap equivalent to two character periods at the serial port baud rate is treated as a message end. The first character received after such a gap is treated as the first character of the next message.

When RFT ROUTING mode is enabled the "NETWORK ID" and "RADIO ADDRESS" fields must be filled out such that every radio in a system has the same network id, but a different radio address. Notes should be kept detailing the installation of radios and their addresses.

The master station radio must be programmed with a routing table, this is accessed in the "EDIT MODEM/INTERFACE" menu by setting "ROUTING TABLE" to "ON" and selecting "EDIT ROUTING TABLE". This selection leads to several pages of protocol addresses, the route by which every protocol address is reached must then be entered, for example if the device with protocol address 37 is physically connected to the radio with radio address 23, and radio 23 is accessed from the base station via relay radios 4 and 19, then the field entitled "ADDR 37" should be loaded with the route "4,19,23". If the devices with protocol addresses 65 and 93 are physically connected to radio 45 and no relays are required then the fields entitled "ADDR 65" and "ADDR 93" should both be loaded with "45".

If no routing table is loaded or a protocol address cannot be found in the routing table the radio assumes that the destination radio address is the same as the protocol address and that no relays are required. This can be taken advantage of in simple schemes where no more than one device is connected to any one radio.

#### 4.9.2 POWER SAVE OPERATION WITH RFT ROUTING

When RFT ROUTING mode is enabled in the A4P programme two further fields appear entitled "MIN PWR SAVE ADDRESS" and "MAX PWR SAVE ADDRESS", if power save operation is not required set both these fields to zero.

If power save operation is required it is enabled by setting the "RADIO ADDRESS" to a value greater or equal to "MIN PWR SAVE ADDRESS" and less than or equal to "MAX PWR SAVE ADDRESS". The radio will then enter low power standby mode for the time programmed in the "PSAVE ON TIME" field in the main edit menu, it will then wake up and check for an incoming signal, if none is present it will return to sleep and repeat the cycle. If a signal is detected the radio will stay awake until a reply to the outward bound message has been returned.

When the master station or relay radios send an outward bound message, the address of the radio to which the message is being sent is checked against the min and max power save addresses, if a power saved radio is indicated a cyclic wake up message is sent for the period indicated by the programmed power save on time before the actual data message is sent, if a power saved radio is not indicated the data message is sent immediately. These parameters along with some others are also used to calculate a timeout time in the event that no reply is received. It is therefore essential that all radios in a system are programmed with the same parameters even if not power saved, otherwise communications will fail.

Note that if "DTR SHUTDOWN" is enabled a radio remains completely shut down while DTR is inactive, it will not wake up according to the power save timer to see if any incoming messages are present. This mode should therefore only be used in conjunction with real time message scheduling.

#### 4.9.3 SERIAL PORT HANDSHAKING WITH RFT ROUTING

When RFT ROUTING mode is enabled the RS232 port lines DTR, DSR and RI, can be used to assist in power saving the host device. The RTS and CTS lines are optionally used according to the "RTS/CTS HANDSHAKE" option in the "EDIT MODEM/INTERFACE" menu for flow control. The RI (ring indicator) line is asserted when a radio detects an incoming message, it can be used to wake up an outstation slave device, when the slave is ready to accept data it should assert DTR, DSR will be asserted in response and the received message will be output to the device. The "HOST INACTIVITY TIME" field in the set up programme defines a time limit for the device to assert DTR in response to RI, if this time limit is exceeded RI is dropped and the radio sends back a reply indicating the destination device failed to respond and the link is cancelled (this message is not output to the device connected to the master station serial port). This time is also used to define the time limit for the device to reply to the incoming message, if the time limit is not exceeded the reply is sent back to the master station and RI is dropped. The slave may then release DTR and return to power save mode. Note that as long as DTR is asserted the radio will not return to its power save mode (if enabled in the setup programme). DSR will remain asserted in this case.

The master station can also control the power saving of its radio using DTR, the radio will operate in power save mode as long as DTR is not active, asserting DTR wakes the radio, DSR is asserted in return to indicate that the radio is awake and ready to accept data.

If use of the handshake lines is not required DTR should be connected either to a voltage of +3.5 to +15V such that sleep mode is never allowed or at slave sites it can be connected to RI so that the radio stays awake as long as RI is asserted.

#### 4.9.4 TIMEOUTS IN RFT ROUTING MODE

When a transmission from a master station radio is made in RFT ROUTING mode the radio will calculate a timeout for a reply, this calculation is based on many configuration parameters including the radio baud rate, lead in delay, host inactivity time, maximum message length, power save timing etc. If power saving is enabled and the baud rate is low this time can be large (the calculation limits the result to a maximum of 4.25 minutes. To reduce the possibility of "hung" radios the destination radio will send a link closing message if the destination slave does not reply. This link closing message is only used by the radios to close the link, it is not passed to the device connected to the master station radio.

If the device connected to the master station radio itself times out before the radio link does, it can send another poll, radios along the link will cancel the previous route and set up the new one. The exception to this is the previous destination radio if it is still trying to wake up its slave, it will ignore the new message and try to download its original message when the slave awakes, a conflict will then arise if a reply is sent. To avoid this situation the master timeout time should allow the maximum "HOST INACTIVITY TIME" to expire plus the time required to get a message and its reply through the link.

# 5

# PROGRAMMING

## 5.1 INTRODUCTION

The SRT Series can be programmed with any PC operating DOS via a standard 9W – 9W RS232 cable. The programming software is available on either a 3.5inch floppy or CD ROM and will allow the user to configure the product to work within many systems.

*At the time of writing this manual a Windows version is under development.*

## 5.2 SRP PROGRAMMING SOFTWARE VERSIONS

There are various versions of SRP programming software, these are:

SRP_	Standard client copy
SRP_R	Standard client copy with Remote Network Management software
SRP_F	Factory Version
SRP_FR	Factory Version with Remote Network Management software
SRP_DFR	Full demo version

## 5.3 CONFIGURATION OF THE SRP PROGRAM

To set up the programme for your computer put the supplied disc into the drive and type "SRP\_/C"(If there is an extension after the under score as outlined in 5.2 add it in), the /C extension causes the configuration mode to be entered. The programme provides the user with instructions about what to do and allows set up for the type of screen in use and selection of either comms port 1 or 2 for programming.

## 5.4 STARTING THE PROGRAM.

To start the programme, put the supplied disc in the drive and type "SRP", if the program contains the "Network Management" option the start command will be "REMSRP"

(Note: hard disc users may wish to run the programme from hard disc, to do this copy the files named SRP.EXE, RP.CFG and DEFAULTS.DAT to the appropriate directory and proceed as for a floppy drive, if RP.CFG is not present it may be created by entering the configuration mode by typing "SRP/C". On starting, the programme will load and display the opening menu.

## 5.5 LOCAL PC PROGRAMMING

Connect the SRT product to the designated PC's comms port via a normal 9Way to 9Way RS232 cable and select "00" on the two front panel switches, selecting **Channel "00"** puts the SRT in local program mode. After programming ensure the switches are changed to reflect the required RF channel.

## 5.6 OPENING MENU

```
EDITING FILE 'NONAME'  
  
PROGRAM RADIO  
READ RADIO  
LOAD PROGRAM FROM DISC  
SAVE PROGRAM TO DISC  
EDIT PROGRAM  
EDIT NOTES  
PRINT PROGRAM  
ERASE PROGRAM  
CALIBRATE  
NETWORK MANAGEMENT  
QUIT  
USE CURSOR KEYS TO MOVE AROUND SCREEN  
SELECT OPTIONS WITH ENTER KEY
```

"Arrow Keys" are used to move round the menu and the RETURN key is used to make the selection required. Whenever a programme is produced for a Radio Modem, it may be given a name and stored and retrieved from disc by using the SAVE TO DISC and LOAD FROM DISC options.

### 5.6.1 PROGRAMME VERSION NUMBER & COMPATIBILITY MESSAGE

If new fields are added or changes are made to the PC program, the version number changes but in most cases a new program will program older radios. To complicate matters more, over time there will be changes and upgrades to the firmware in the radio which may not be compatible with older PC programming software. To overcome this, each modem has a compatibility serial number which is changed at the factory if and when the firmware changes. If the product and PC software is not compatible, as a safety precaution the PC will not read or write to the modem but will display a compatibility error message. If this happens a different edition of PC programming software with the same compatibility number may be required.

### 5.6.2 PROGRAMME RADIO/READ RADIO

To read or programme the radio both Switches on the front of the modem should be set to zero (0). The radio data can be read via the "Read Radio" function or programmed via the "Program Radio" function.

**Note:** *Always read the radio first as the PC will read and display the RF power & Alignment range as well as the other factory programmed parameters.*

When programming/reading has finished the screen reverts to normal.

Normal operation of the radio is resumed when the channel switches are set to a valid channel number.

### **5.6.3 LOAD PROGRAM FROM DISC**

When "Load Program From Disc" is selected it is possible to display the directory containing the relevant programs by following the prompt at the bottom of the screen. CTRL "D" is used to select the required directory and pressing "ESCAPE" returns the Opening Menu screen.

### **5.6.4 SAVE PROGRAM TO DISC**

Enables the operator to save the program to disc for future use.

### **5.6.5 EDIT NOTES**

The PC program has a text editor accessed from the main menu that will allow the user to enter the unit's hard link configuration and add notes if required. The file has defaults but these can be over typed and changed as required. The print command will print the notes together with all the programmed parameters.

### **5.6.6 PRINT PROGRAM**

Prints the selected parameters for a hard copy record

### **5.6.7 ERASE PROGRAM**

Simply erases the parameters selected by the user and returns to the default program

### **5.6.8 CALIBRATE**

*The calibrate options screen is primarily used for factory programming, although one or two fields are available to the user and are explained further on in this section.*

### **5.6.9 NETWORK MANAGEMENT (OPTION)**

This software is optional and enables the user to remotely program the radio and configure the network over the radio links, it also contains some very powerful diagnostic and re-alignment features.

### **5.6.10 QUIT**

This returns the user to the DOS prompt.

## 5.7 DESCRIPTION OF MAIN MENU EDIT FUNCTIONS:

### 5.7.1 MAIN MENU

```
EDITING FILE 'NONAME'
.....
RETURN TO MAIN MENU
EDIT CHANNEL DATA
EDIT MODEM/INTERFACE
FREQUENCY RANGE MPT1329
CHANNEL SELECT MODE INCREMENTAL
NUMBER OF CHANNELS 37
CHAN SWITCH OVERRIDE DISABLED
CHANNEL INCREMENT 12.5kHz
RX START FREQUENCY 458.50000
TX START FREQUENCY 458.50000
POWER RANGE 10mW-1W
TRANSMIT POWER 0.100
PSAVE ON TIME (s) 0.00
PSAVE OFF TIME (ms) 50
PSAVE RESUME TIME (s) 0
LOCKOUT TIMER MODE RESETTABLE
LOCKOUT TIME (s) 0
SERIAL NUMBER
NOTEPAD
ALIGNMENT RANGE F3 455-465MHz 12.5kHz
USE CURSOR KEYS TO MOVE AROUND SCREEN
SELECT OPTIONS WITH ENTER KEY
```

To edit the radio modem programme data select "EDIT PROGRAMME" and the menu above will be displayed: The up/down arrow keys are used to move the cursor round the fields on the screen. To change a field press the RETURN key and then select the data with the left/right arrow keys. Some fields will require you to type in data, e.g. channel Numbers or channel frequencies. After confirming the selected data is correct press the RETURN key to enter. If you want to change the data once it's been entered, just move the cursor to the desired field and press RETURN. You can then repeat the operation.

### 5.7.2 FREQUENCY RANGE

This selects the frequency range and covers the discrete VHF, UHF and 900MHz bands, or specific telemetry band allocations used in various countries.

*To check the programmable range of the product connected, look at the Alignment Range field.*

VHF	138 - 155MHz 150 - 175MHz 175 - 225MHz
UHF	406 - 475MHz
900MHz	820 - 950MHz
UK Pre-set	MPT1411/VNS2111 Outstation MPT1411/VNS2111 Scanner MPT1329

### 5.7.3 ALIGNMENT RANGE

This reads the factory aligned programmable range and the channel spacing from the connected radio.

e.g. F3 458 – 460MHz 12.5KHz

or

TX F3 458 – 470MHz, RX F2 430 – 442MHz 12.5KHz

### 5.7.4 CHANNEL SELECTION MODE

There are two ways of setting up channels on the radio, in INCREMENTAL mode a start frequency for both RX and TX is set up along with a channel increment and the desired number of channels, for example entering 450MHz as the RX and TX start frequency, 5 as the number of channels, and 12.5KHz as the channel increment, will result in frequencies of 450.0000, 450.0125, 450.0250, 450.0375, and 450.0500 being allocated to channels 1 to 5 of the modem, the TX and RX frequencies can be offset by using different start frequencies. Up to 80 channels can be programmed in this way. (Note that selection of MPT1329 or MPT1411 for frequency range forces use of incremental mode and inhibits alteration of the number of channels or their spacing). In DISCRETE mode channel frequencies may be explicitly entered in the channel data and do not have to conform to any regular spacing.

#### 5.7.4.1 Number of Channels

This option sets the number of channels required in INCREMENTAL channel selection mode; it is suppressed when the mode is set to DISCRETE. See the section on CHANNEL SELECTION MODE for more detail.

#### 5.7.4.2 Channel Increments

This option sets the channel spacing required in INCREMENTAL channel selection mode; it is suppressed when the mode is set to DISCRETE. See the section on CHANNEL selection for more detail.

#### 5.7.4.3 RX Start Frequency

This option sets the channel one RX frequency required in INCREMENTAL channel selection mode, all subsequent channels are spaced above this frequency separated by the CHANNEL INCREMENT, it is suppressed when the mode is set to DISCRETE. See the section on CHANNEL SELECTION MODE for more detail.

#### 5.7.4.4 TX Start Frequency

This option sets the channel one TX frequency required in INCREMENTAL channel selection mode, all subsequent channels are spaced above this frequency separated by the CHANNEL INCREMENT, it is suppressed when the mode is set to DISCRETE. See the section on CHANNEL SELECTION MODE for more detail.

### 5.7.5 POWER RANGE

This option is used to select either the 10mW - 1Watt or 50mW - 5Watt transmitter version.

Note: In the one watt range with an SRT connected, the maximum programmable power level is 750mW

### 5.7.6 TX POWER

The required transmitter power in watts can be entered in this field. For example 1.32Watts or 0.05 Watts.

**NOTE:** *Programming an SRT to a RF power level exceeding local regulations is strictly forbidden and may lead to prosecution. R.F. Technologies is not responsible for any illegal use of it's products and is in no way is responsible for any claims or penalties arising from*

*its operation in ways that contravene local regulations .*

## **5.7.7 POWER SAVE OPTIONS**

The save on, save off and resume time are all programmable parameters to provide further power saving features.

### **5.7.7.1 Save On Time**

This is for power save programming and sets the time the transceiver is switched off for during the power save cycle (Power Save On). The Save On Time is programmable from 0 - 63.75 Seconds in 250ms (1/4 second) steps. A setting of 0 disables power save.

### **5.7.7.2 Save Off Time**

This is for power save programming and sets the time the transceiver is switched on for during the power save cycle (Power Save Off). The Save Off Time is programmable from 0 - 2550 in 10ms steps. The default setting is 50ms.

### **5.7.7.3 Save Resume Time**

When a carrier is received during power save mode, the unit will come out of its power save mode to receive the signal. The Resume Time, is the time the receiver stays active after the received carrier has dropped out, i.e. the time power save mode is deferred. This is programmable between 0 - 255 seconds in 1 second steps.

## **5.7.8 SERIAL NUMBER**

The serial number may not be altered using the set up program, it does however provide the user with the means to read it.

## **5.7.9 NOTE PAD**

The notepad provides a facility for storing up to 48 ASCII characters in the modem's memory such as its location or ownership etc.

## **5.7.10 LOCKOUT TIME MODE**

Selectable either re-settable or cumulative, for a full description see section 6.17

## **5.7.11 LOCKOUT TIME**

Selects the transmit timeout timer period, 0 - 255 seconds in one second steps.

## **5.7.12 MENU OPTIONS**

### **5.7.12.1 Return to Main Menu**

As suggested this function returns to the Main Menu.

### **5.7.12.2 Edit Channel Data**

This field takes you into the Channel data Screen

### **5.7.12.3 Edit Modem/Interface**

This field takes you into the modem and interface menu

### 5.7.13 LEADOUT DELAY

The lead out delay is the time the transmitter stays up after the audio data finishes, this is to avoid mute noises that could corrupt data that is not framed, packeted and does not have an end of message character. This is programmable between 0 & 256milli seconds

## 5.8 MODEM/INTERFACE EDIT MENU

```

EDITING FILE 'NONAME'
RADIO BAUD RATE      1200
RADIO DATA BITS     8
RADIO PARITY         NONE
RADIO STOP BITS      1
FFSK TONE SET        BELL 202
FFSK SYNC/ASYNC      SYNCHRONOUS
SERIAL BAUD RATE     1200
SERIAL DATA BITS    8
SERIAL PARITY        NONE
SERIAL STOP BITS     1
RTS/CTS HANDSHAKE    OFF
DCD OPERATION        CARRIER+DATA
DTR SHUTDOWN         OFF
LEAD IN DELAY (ms)  40
LEAD OUT DELAY (ms)  0
INTERFACE PROTOCOL   NONE
MESSAGE PACKETING    OFF
FWD ERROR CORRECTION OFF
RETURN TO EDIT MENU
USE CURSOR KEYS TO MOVE AROUND SCREEN
SELECT OPTIONS WITH ENTER KEY

```

```

EDITING FILE 'NONAME'
RADIO BAUD RATE      9600
RADIO DATA BITS     8
RADIO PARITY         NONE
RADIO STOP BITS      1
FFSK SYNC/ASYNC      SYNCHRONOUS
SERIAL BAUD RATE     9600
SERIAL DATA BITS    8
SERIAL PARITY        NONE
SERIAL STOP BITS     1
RTS/CTS HANDSHAKE    OFF
DCD OPERATION        CARRIER+DATA
DTR SHUTDOWN         OFF
LEAD IN DELAY (ms)  30
LEAD OUT DELAY (ms)  0
INTERFACE PROTOCOL   NONE
MESSAGE PACKETING    OFF
FWD ERROR CORRECTION OFF
RETURN TO EDIT MENU
USE CURSOR KEYS TO MOVE AROUND SCREEN
SELECT OPTIONS WITH ENTER KEY

```

### 5.8.1 RADIO BAUD RATE

Sets the baud rate of the internal radio modem, (currently 150 - 9600 baud within the prescribed 12.5KHz channel) this setting does not govern the speed at which the serial port operates which should be set either at the same speed or a higher speed. The radio baud rate should be set at the minimum possible to maintain the required throughput, lower speeds will give better results in poor signal conditions.

### **5.8.2 RADIO DATA BITS**

Selects either 7 or 8 bits

### **5.8.3 RADIO PARITY**

Selects none, even or odd

### **5.8.4 RADIO STOP BITS**

Selects either 1 or 2.

### **5.8.5 FFSK TONE SET**

At speeds between 150 & 1200bps either Bell 202 or V23 mode 2 tone sets can be selected Bell 202 tones should be selected if possible since their wider separation yields slightly better performance. Above 1200 the data format is fixed.

### **5.8.6 FFSK SYNC/ASYNC**

At speeds between 150 - 1200bps either synchronous or asynchronous can be selected, above 1200 baud the format is fixed as Synchronous. For best performance synchronous mode is suggested.

### **5.8.7 SERIAL BAUD RATE**

The serial port baud rate may be set independently from the radio baud rate in the range 150 to 38400bps. The setting should always be the same speed or higher than the radio baud rate.

### **5.8.8 SERIAL DATA BITS**

Selects either 7 or 8 data bits for the serial port.

### **5.8.9 SERIAL PARITY**

Selects: none, odd or even parity for the serial port.

### **5.8.10 SERIAL STOP BITS**

Selects 1 or 2 stop bits for the serial port.

### **5.8.11 RTS/CTS HANSHAKE**

On or Off can be selected

### **5.8.12 DCD OPERATION**

This option is used in conjunction with the internal modem and is used to select DCD line active on detection of RF Only or RF and Data.

### **5.8.13 DTR SHUTDOWN**

Enables DTR to be used for external power save, in this mode the on/off ratio is controlled externally via the DTR line (DTR shut down must first be enabled using the set up program). In this mode more of the modem's circuits are shutdown (including the microprocessor), this saves more power but care must be taken to ensure that the modem is enabled when a transmission is to take place. Note that there is a hardware link option to allow the serial port to shut off when DTR is not active; this allows the radio current to be reduced to its bare minimum. In applications where DTR is not connected this link option must of course be disabled.

### **5.8.14 LEAD IN DELAY**

Selects the time the RF carrier is raised before the transmission of data via the internal modem takes place, for more detail see the section of this manual describing transmit/receive timing. The delay is programmable from 0 to 2500ms in 10ms steps.

### 5.8.15 LEAD OUT DELAY

Selects the time the transmitter remains up after the data has been sent. Used sometimes to give a finite quiet pause after the data has been sent, for more detail see the section of this manual describing transmit/receive timing. The delay is programmable from 0 to 2500ms in 10ms steps.

### 5.8.16. INTERFACE PROTOCOL

The interface protocol can be used to select NONE, HAYES AT, MODBUS RTU, MODBUS ASCII, DNP3 & IEC870. At the time of writing this version of the manual DNP3 & IEC870 are still under development. For further information on Hayes & MODBUS see the protocol section of the manual.

### 5.8.17 MESSAGE PACKETING

The message packeting as the name suggested packets the message to Eliminate squelch tail noises in systems where there cannot be tolerated

### 5.8.18 FORWARD ERROR CORRECTION

Forward error correction is a programmable option at 9600bps and will improve the BER in areas of poor performance, however there is approximately a data through put overhead of 30%.

### 5.8.19 NETWORK I.D. ADDRESS

The Network I.D can consist of up to 5 digits and differentiates one network or a sub network from another.

### 5.8.20 RADIO ADDRESS

The Radio Address is the actual address of the radio modem as used in HAYES, MODBUS and for remote programming.

## 5.9 HAYES "AT" SELECTION

If Hayes "AT" selection has been made the following options will appear on the screen, for a more in depth explanation of the programming options see the Hayes "AT" information in the protocol section

```
EDITING FILE 'NONAME'
RADIO BAUD RATE      9600
RADIO DATA BITS     8
RADIO PARITY         NONE
RADIO STOP BITS      1
.....
FFSK SYNC/ASYNC     SYNCHRONOUS
SERIAL BAUD RATE     9600
SERIAL DATA BITS    8
SERIAL PARITY        NONE
SERIAL STOP BITS     1
RTS/CTS HANDSHAKE   OFF
DCD OPERATION        CARRIER+DATA
DTR SHUTDOWN         OFF
LEAD IN DELAY (ms)  30
LEAD OUT DELAY (ms)  0
RETURN TO EDIT MENU
INTERFACE PROTOCOL  HAYES AT
MESSAGE PACKETING   ON
FWD ERROR CORRECTION OFF
NETWORK I.D.        1234
RADIO ADDRESS       1
AUTO ANSWER TIME (s) 2
ESC CHARACTER CODE   43
ESC GUARD TIME (ms) 1000
MIN PWR SAVE ADDRESS 128
MAX PWR SAVE ADDRESS 255
HOST INACTIVITY TIME 10
USE CURSOR KEYS TO MOVE AROUND SCREEN
SELECT OPTIONS WITH ENTER KEY
```

### 5.9.1 AUTO ANSWER TIME (s)

The auto answer time can be programmed between 0 & 255 Seconds in 1 second steps

### 5.9.2 ESC CHARACTER CODE

The Escape Character code is a Decimal ASCII code between 0 - 255 which is normally 43 for a "+" sign

### 5.9.3 ESC GUARD TIME (mS)

The Escape guard time can be programmed between 0 - 5100mS in 20mS steps

### 5.9.4 MIN & MAX PWR SAVE ADDRESS

To enable power save the "Radio Address must be greater than or equal to the "Min Pwr Save Address" or Less than or equal to the "Max Pwr Save Address.

### 5.9.5 HOST INACTIVITY TIME

The Host inactivity time is the time a radio will wait for its host to wake up after raising RI, if auto answer is disabled. The radio can be programmed between 0 -255 seconds in 1 second increments.

## 5.10 MODBUS SELECTION

If MODBUS selection has been made the following options will appear on the screen, for a more in depth explanation of the programming options see the MODBUS information in the protocol section

```
EDITING FILE 'NONAME'
RADIO BAUD RATE      9600
RADIO DATA BITS     8
RADIO PARITY         NONE
RADIO STOP BITS      1
.....
FFSK SYNC/ASYNC     SYNCHRONOUS
SERIAL BAUD RATE     9600
SERIAL DATA BITS    8
SERIAL PARITY        NONE
SERIAL STOP BITS     1
RTS/CTS HANDSHAKE    OFF
DCD OPERATION        CARRIER+DATA
DTR SHUTDOWN         OFF
LEAD IN DELAY (ms)  30
LEAD OUT DELAY (ms) 0
.....
RETURN TO EDIT MENU
INTERFACE PROTOCOL   MODBUS RTU
MESSAGE PACKETING    ON
FWD ERROR CORRECTION OFF
NETWORK I.D.         1234
RADIO ADDRESS        1
.....
MIN PWR SAVE ADDRESS 128
MAX PWR SAVE ADDRESS 255
HOST INACTIVITY TIME 10
.....
ROUTING TABLE       ON
EDIT ROUTING TABLE
.....
USE CURSOR KEYS TO MOVE AROUND SCREEN
SELECT OPTIONS WITH ENTER KEY
```

### 5.10.1 INTERFACE PROTOCOL

The interface protocol can either be set for MODBUS RTU or ASCII, with MODBUS selected the MESSAGE PACKETING will always default to ON.

### 5.10.2 FORWARD ERROR CORRECTION

Forward error correction is a programmable option at 9600bps and will improve the BER in

areas of poor performance, however there is approximately a data through put overhead of 30%.

### 5.10.3 NETWORK I.D.

The Network ID can be any number between 1-65535

### 5.10.4 RADIO ADDRESS

Address of the radio can be any number between 1-255

### 5.10.5 MIN & MAX PWR SAVE ADDRESS

To enable power save the "Radio Address must be greater than or equal to the "Min Pwr Save Address" or Less than or equal to the "Max Pwr Save Address.

### 5.10.6 ROUTING TABLE

The is an on/off selection to bring up the Edit Routing Table menu

### 5.10.7 EDIT ROUTING TABLE

Clicking on this field will take the operator into the edit menu for the routing tables, for further information see the MODBUS information in the protocol section.

## 5.11 ROUTING TABLE MENU

EDITING FILE 'NONAME'		
<b>PAGE UP</b>		<b>EXIT</b>
MBUS 64		MBUS 80
MBUS 65		MBUS 81
MBUS 66		MBUS 82 55
MBUS 67		MBUS 83 55
MBUS 68 2,3,4,20		MBUS 84 55
MBUS 69 2,3,4,20		MBUS 85 55
MBUS 70		MBUS 86
MBUS 71		MBUS 87
MBUS 72		MBUS 88
MBUS 73 2,3,14		MBUS 89
MBUS 74 2,3,14		MBUS 90 2,3,4,21
MBUS 75 2,3,14		MBUS 91
MBUS 76		MBUS 92
MBUS 77		MBUS 93
MBUS 78		MBUS 94
MBUS 79		MBUS 95
<b>PAGE DOWN</b>		
<b>USE CURSOR KEYS TO MOVE AROUND SCREEN SELECT OPTIONS WITH ENTER KEY</b>		

The Routing Table enables the operator to program a route into the Radio, further details are in the MODBUS protocol section.

## 5.12 RFT ROUTING SELECTION

If RFT Routing selection has been made the following options will appear on the screen, for a more in depth explanation of the programming options see the RFT Routing information in the protocol section

EDITING FILE 'NONAME'			
RADIO BAUD RATE	9600	RETURN TO EDIT MENU	
RADIO DATA BITS	8		
RADIO PARITY	NONE	INTERFACE PROTOCOL	RFT ROUTING
RADIO STOP BITS	1	MESSAGE PACKETING	ON
.....		FWD ERROR CORRECTION	OFF
FFSK SYNC/ASYNC	SYNCHRONOUS	NETWORK I.D.	1234
		RADIO ADDRESS	1
SERIAL BAUD RATE	19200	.....	
SERIAL DATA BITS	8	ADDRESS OFFSET	43
SERIAL PARITY	NONE	.....	
SERIAL STOP BITS	1	MIN PWR SAVE ADDRESS	128
RTS/CTS HANDSHAKE	ON	MAX PWR SAVE ADDRESS	255
DCD OPERATION	CARRIER+DATA	HOST INACTIVITY TIME	10
DTR SHUTDOWN	OFF		
LEAD IN DELAY (ms)	30	<b>ROUTING TABLE</b>	ON
LEAD OUT DELAY (ms)	0	EDIT ROUTING TABLE	
USE CURSOR KEYS TO MOVE AROUND SCREEN SELECT OPTIONS WITH ENTER KEY			

### 5.12.1 INTERFACE PROTOCOL

The interface protocol should be set to RFT ROUTING, with RF ROUTING selected the MESSAGE PACKETING will always default to ON.

### 5.12.2 FORWARD ERROR CORRECTION

Forward error correction is a programmable option at 9600bps and will improve the BER in areas of poor performance, however there is approximately a data through put overhead of 30%.

### 5.12.3 NETWORK I.D.

The Network ID can be any number between 1-65535

### 5.12.4 RADIO ADDRESS

Address of the radio can be any number between 1-255

### 5.12.5 ADDRESS OFFSET

The Address offset can be set to ant number between 1 -255

### 5.12.6 MIN & MAX PWR SAVE ADDRESS

To enable power save the "Radio Address must be greater than or equal to the "Min Pwr Save Address" or Less than or equal to the "Max Pwr Save Address.

### 5.12.7 ROUTING TABLE

The is an on/off selection to bring up the Edit Routing Table menu

### 5.12.8 EDIT ROUTING TABLE

Clicking on this field will take the operator into the edit menu for the routing tables, for

further information see the RF Routing information in the protocol section.

### 5.12.9 RFT ROUTING TABLE MENU

```
EDITING FILE 'NONAME'

PAGE UP                                EXIT
ADDR 0 12,77,88,99                    ADDR 16
ADDR 1                                  ADDR 17
ADDR 2                                  ADDR 18
ADDR 3                                  ADDR 19
ADDR 4                                  ADDR 20
ADDR 5                                  ADDR 21
ADDR 6                                  ADDR 22
ADDR 7                                  ADDR 23
ADDR 8                                  ADDR 24
ADDR 9                                  ADDR 25
ADDR 10                                 ADDR 26
ADDR 11                                 ADDR 27
ADDR 12                                 ADDR 28
ADDR 13                                 ADDR 29
ADDR 14                                 ADDR 30
ADDR 15                                 ADDR 31

PAGE DOWN

USE CURSOR KEYS TO MOVE AROUND SCREEN
SELECT OPTIONS WITH ENTER KEY
```

The Routing Table enables the operator to program a route into the Radio, further details are in the RFT Routing protocol section.

### 5.13 EDIT CHANNEL DATA SCREEN

```
EDITING FILE 'NONAME'

RX FREQUENCY (MHZ)    459.00000    EDITING CHANNEL 1
TX FREQUENCY (MHZ)    457.00000
                                                                RETURN TO EDIT MENU
                                                                NEXT CHANNEL
                                                                PREVIOUS CHANNEL

USE CURSOR KEYS TO MOVE AROUND SCREEN
SELECT OPTIONS WITH ENTER KEY
```

### 5.13.2 DESCRIPTION OF CHANNEL DATA MENU FUNCTIONS:

The channel data screen is displayed when "EDIT CHANNEL DATA" is selected from the main edit menu. Up to 32 channels may be edited in discrete channel selection mode, and up to 80 in incremental mode. The channel number displayed at the top right of the screen corresponds to the channels that may be selected by the bcd channel switches in the modem. The channels can be stepped through one by one using the NEXT and PREVIOUS CHANNEL options.

### 5.13.3 RX & TX FREQUENCY

In incremental channel selection mode the frequencies are displayed for information purposes only and may not be edited, in discrete mode each frequency must be explicitly entered. For convenience the TX frequency can be made the same as the RX frequency by hitting the space bar when prompted for an entry.

### 5.13.4 NEXT/PREVIOUS CHANNEL

By pressing the Enter key the next or previous channel is displayed.

### 5.13.5 EDITING CHANNEL

Press the Enter key and then use the Arrow keys to select the required channel number, then press the Enter key again to display the channel information.

## 5.14 CALIBRATE MENU (FACTORY & SERVICE CENTRE OPTION)

Only the Line input level, Line output level, RSSI Test, Input Voltage Test & Temperature Test options within this menu are available to users; the other functions are for factory alignment only and have been inhibited on the normal issue of software.

```
EDITING FILE 'NONAME'  
  
TEST MAX POWER/MOD BALANCE          RETURN TO MAIN MENU  
SET TX FREQUENCY  
SET RX FREQUENCY                    CAL RSSI/RX TUNING  
CALIBRATE POWER                     RSSI/RX TUNING TEST  
SET PEAK DEVIATION                 TEMP/PSU TEST  
CAL INT MOD/TX TUNING  
SET LINE INPUT LEVEL  
SET LINE OUTPUT LEVEL  
  
USE CURSOR KEYS TO MOVE AROUND SCREEN  
SELECT OPTIONS WITH ENTER KEY
```

### 5.14.1 TEST MAX POWER/MOD BALANCE

This selects the maximum power for TX alignment and modulates the Transmitter with a 50Hz square wave to balance the modulation point.

### 5.14.2 SET TX FREQUENCY

This adjusts the transmitter's frequency by varying the voltage to the VCTCXO. It is normally set to the mid point +/-2.5V and the frequency is then set up with the variable capacitor in the VCTCXO. This enables later electronic adjustment to be carried out via a PC or over the radio link.

#### **5.14.3 SET RX FREQUENCY**

This adjusts the receiver's frequency by varying the voltage to the VCTCXO. It is normally set to the mid point +/-2.5V and the frequency is then set up with the variable capacitor in the VCTCXO. This enables later electronic adjustment to be carried out via a PC or over the radio link.

#### **5.14.4 CALIBRATE POWER**

Following the menu, the operator adjusts the power output via the arrow keys and enters requested levels. These levels are used to calibrate the particular RF power profile of the individual product. This profile is then used to accurately select the required RF power level via the PC program or over the radio link.

#### **5.14.5 SET PEAK DEVIATION**

Using the up/down arrow keys the peak deviation level is set for the required channel spacing.

#### **5.14.6 CAL RSSI**

With a single generator connected to the radio modem, the operator adjusts the output level as requested by the program and each level is entered into the products memory. These levels are used to build up a calibration profile of the RSSI response of individual products. The profile is then used to accurately measure the RSSI level of any received signal and display the value in dBuV on a PC.

#### **5.14.7 RSSI TEST**

Will read the incoming signal level (RSSI) and will display the value within the range of -15 to +30dBuV for antenna alignment and range testing.

#### **5.14.8 RETURN TO MAIN MENU**

Simply returns the user to the Main Menu

## 5.15 NETWORK MANAGAMENT

The Network Management option if installed enables the operator to manage all the radios within the network from a single point via a PC

```
EDITING FILE 'NONAME'

DESTINATION RADIO      20          PROGRAM REMOTE RADIO
1ST RELAY RADIO        2          READ REMOTE RADIO
2ND RELAY RADIO        3          EDIT PROGRAM
3RD RELAY RADIO        4          ROUTE DIAGNOSTICS
4TH RELAY RADIO        -          TUNE ALL RADIOS
5TH RELAY RADIO        -          REMOTE FIRMWARE DOWNLOAD
6TH RELAY RADIO        -          RETURN TO MAIN MENU

USE CURSOR KEYS TO MOVE AROUND SCREEN
SELECT OPTIONS WITH ENTER KEY
```

### 5.15.1 DESTINATION RADIO

The destination radio is the address of the radio that the user wants to communicate with.

### 5.15.2 1<sup>st</sup> - 6<sup>th</sup> RELAYS

The relays are the radios in between base station & the destination radio, in other words the route to get to the destination radio.

### 5.15.3 PROGRAM RADIO

This command will remotely program the destination radio over the radio link with the new edited program

### 5.15.4 READ RADIO

This command will remotely read the program within the destination radio over the radio link

### 5.15.5 EDIT PROGRAM

This command brings up the editing program to enable changes to be made

### 5.15.6 ROUTE DIAGNOSTICS (Available on the ART only)

The route diagnostics menu will display the RF power settings, received signal strength, any frequency offset from the base station, Internal temperature, Input Voltage and I.O. conditions at each of the units in the link between the base station and the destination radio. It also enables the operator to adjust the RF power of destination and base station radio, to re-establish the correct signal strengths in the link and toggle the digital outputs.

### 5.15.7 TUNE ALL RADIOS (Available on the ART only)

The tune all radios command will trim the frequency of the receiver and transmitter modules contained in each ART throughout the link to match that of the base station. This is fully automated and requires no input from the operator.

#### **5.15.8 REMOTE FIRMWARE DOWNLOAD (Available on the ART only)**

The remote firmware download is used to download new firmware securely over the radio link to a specific radio, number of radio or the complete network of radios.

#### **5.15.9 RETURN TO MAIN EDIT MENU**

Returns the user to the main menu.

7

# INSTALLATION

## 6.1 INTRODUCTION

The SRT Series are DIN rail mountable Radio Modems/Store & Forward Repeater for outstation applications. & with correct installation should ensure reliable data communications for many years.

The most important installation points to remember are:

Suitable antenna system mounted at the correct height & polarisation to achieve the required distance.

Reliable power supply capable of supplying the correct voltage and current.

Correct installation for the environment

Correct interface and set-up

Assuming the unit has been correctly installed and tested at the correct data speed, the only other factors that will effect the performance, are the RF power, (Normally Specified by the regulating authority), the local topography and the weather, none of which the user can control.

## 6.2 POWER SUPPLIES

The SRT series can be powered from any power source providing the voltage is between 9.6VDC & 16VDC -VE GND. If a +VE GND system is in use, an isolated converter will be required.

The SRT Series is available in either 10mW - 1Watt or 20mW - 5Watts, which requires a supply current of 1Amp and 2.5Amps respectively.

**Under no circumstances should the output of the supply rise above 16VDC.**

For 240/110VAC, 50VDC or 24VDC, R.F. Technologies produce a range of uninterruptible power supply units with an in-built charger and power fail indication. A range of suitable Gel type batteries is available should a back-up supply be required during power fail.

## 6.3 EFFECTIVE RADIATED POWER (ERP)

The Radio Frequency (R.F.) Power allowed can be specified in two ways:

The "Terminated power into 50 ohms", which in the case of the SRT 5watt product would be a maximum of 5Watts.

The "ERP" is the actual radiated power, taking into account the gain/loss of the antenna and loss in the feeder. Hence, if we use an aerial with a Gain of 3dB (x2) and assume no loss in the cable, the ERP with an input of 5watts would be 10Watts.

The gain of an antenna is very useful as it enables lower power transmitters to be used in many cases in place of high power transmitters, with the advantage of a much lower current consumption.

For example if the ERP allowed for a link is 5Watts, then an SRT 5Watt product operating into a unity gain antenna, would require a supply current of 2Amps to provide an ERP of 5Watts.

If however, we use an 8 element directional Yagi with a Gain of 10dB, we would only need 500mW for the same performance.

With a 5Watt ART product operating at 500mW, we would only require 600mA. Alternatively with a 1Watt ART Product operating at 500mW the current would drop to

350mA. If the site is battery or solar powered then the saving is very significant.

Care must be taken when setting the power within a MPT1329/1411 system, as RF power is specified as maximum ERP.

## 6.4 ANTENNAS, COAX FEEDERS & PERIPHERALS

### 6.4.1 ANTENNAS

Apart from the radio modem, the antenna is probably the most important part of the system. The wrong choice or a bad installation will almost certainly impede the product's performance. Depending on the application either an omni-directional or directional antenna will be required.

### 6.4.2 TYPES OF ANTENNAS

We can offer a complete range of antennas to suit all applications; details of some of the more popular ones are outlined below:

<i>Antenna Types:</i>	<i>Typical Gain</i>	<i>Polarisation</i>	<i>Use</i>
Vertical Whip	0dB	Vertical	In-house testing and local use
Helical	-3dB	Vertical	
End Fed Dipole	0dB	Vertical	Local Scanner or Multi-point system
Folded Dipole	0dB	Vertical/Horizontal	
6dB Co-linear	+6dB	Vertical	Wide area Scanner
3dB Co-linear	+3dB	Vertical	
12 Element Yagi	+12dB	Vertical/Horizontal	Outstation or point to point link
4 Element Yagi	+8dB	Vertical/Horizontal	
Corner Reflector	+10dB	Vertical/Horizontal	Outstations in areas of bad Interference or where radiation
Patch Antenna	0dB	Vertical/Horizontal	Kiosk or Wall mounting

### 6.4.3 DIRECTIONAL ANTENNAS

For point to point communications, a directional Yagi or corner reflector is probably the best type of antenna to use. As directional antennas provide relatively high gain in the forward direction within a limited beamwidth and very good rejection of unwanted signals at the rear. The number of elements and hence the size, will depend on the gain and beam width required. Yagi antennas can be used in the vertical (vertically polarised) or horizontal (Horizontally polarised) but communicating products should be fitted with antennas of the same orientation, if not a loss of signal strength will occur. Vertical and horizontal propagation can be very useful on single or repeater sites where isolation is required between communication paths. Using polarised antennas for each path will increase the isolation

which will reduce possible interference.

#### **6.4.4 OMNI-DIRECTIONAL ANTENNAS**

With approximately 360 degree radiation pattern, this type of antenna is ideal for a scanning station or where communication to a group of widely dispersed outstations is required.

#### **6.4.5 PATCH OR PLATE ANTENNAS**

The patch or plate antennas are normally rectangular or round, with a back plate of aluminium or stainless steel. A polycarbonate or ABS cover is fitted to protect the antenna from the environment. This type of antenna can be produced in different sizes with various radiation patterns to suit the application. Depending on the construction and radiation pattern, the gain is usually between -3dB to + 3dB. Their use is very popular on road side kiosks, buses, trains, aircraft, or where covert communication is required.

#### **6.4.6 ANTENNA MOUNTING**

Location:

The antenna should be mounted in a clear area, as far away as possible from obstructions such as metal constructions, buildings and foliage.

Height:

The ART products operate in the VHF/UHF & 900MHz, which require normal line of sight communication. Hence, for extended ranges the height of the antenna is important.

#### **6.4.7 POLARISATION**

A Yagi or corner reflector antenna can be mounted for vertical or horizontal polarisation. Scanning systems employing a vertically polarised antenna will necessitate the outstation antennas to be of the same orientation. In vertical polarisation the elements are perpendicular to the ground. By mixing polarisation within systems, unwanted signals can be reduced by as much as 18dB. However, such systems require detailed planning.

#### **6.4.8 ALIGNMENT**

If a directional antenna is to be used, it will need alignment with the scanner or communicating station. A map and compass can be used, but the final adjustment should be performed by measuring the receive signal strength (RSSI) from the scanner, as outlined in the operations section.

#### **6.4.9 ANTENNA COAX FEEDER:**

As with the antenna, the use of the wrong coax feeder can seriously affect the performance of the system. Hence, the coax cable should be selected to give a low loss over the distance required. For outstations in the local vicinity of the scanner/ base station, the loss is not very important but for distant stations the loss is very important. As a rule of thumb, never operate a system with a loss of more than 3dB.

To illustrate the point, a 3dB loss in the feeder will result in a 50% loss in transmitted RF power and a 50% reduction in the received signal strength. Therefore, double the received signal strength will be required for the same bit error rate. Although increasing the RF power will compensate for the loss in transmitted power, there is no effective way to improve the received signal strength.

Coax cable should be installed in accordance with the manufacturers' instructions, with cable runs kept as short as possible. Sharp bends, kinks and cable strain must be avoided at all costs. If long term reliability is required, the cable must be securely mounted to avoid excessive movement and longitudinal strain, due to high winds, rain and snow.

#### 6.4.10 SIGNAL LOSS VERSES CABLE LENGTH AT 500MHZ

<i>Cable Type</i>	<i>Attenuation Per 100ft</i>	<i>Attenuation per 100M</i>
RG58	13.0dB	37.0dB
RG213	6.0dB	17.5dB
LDF2-50 3/8inch Foam Helix	2.44dB	8.0dB
LDF4-50 1/2inch Foam Helix	1.60dB	5.26dB
LDF5-50 7/8inch Foam Helix	0.883dB	2.9dB
LDF6-50 1-1/4inch Foam Helix	0.654dB	2.15dB
LDF7-50 1-5/8inch Foam Helix	0.547dB	1.79dB

#### 6.4.11 COAX, CONNECTORS:

50 Ohm coax connectors of a good quality should be used, termination must be in accordance with the manufacturer's specification, any special tools required to terminate the connectors must be used. Connectors exposed to the environment should be sealed to prevent the ingress of moisture. If the cable is penetrated by water a high loss will occur and the cable will need to be replaced. Once assembled it is advisable to test the cable and connectors for open and short circuits.

#### 6.4.12 VSWR MEASUREMENT:

Voltage standing wave ratio (VSWR) is the ratio of detected volts from the forward RF power, to the detected volts from the reflected (returned) RF power. This ratio is used to measure the combined coax cable and antenna match. A good match will ensure that most of the RF Power is radiated, whereas a bad match will result in the reflection of a large amount of the power, thereby reducing the transmitter's range. A perfect match will give a 1:1 ratio and bad match will give 2:1 or higher. For guidance, a good system will measure between 1.2:1 and 1.5:1.

#### 6.4.13 Lightning Arresters

At high or exposed sites, the use of a lightning arrester is recommended. This in-line device fits between the antenna and the product with an earth strap connected to ground. Should a lightning strike occur, most of the energy should be diverted to ground leaving the equipment with little or no damage.

### 6.5 MOUNTING & INSTALLATION

The SRT Series are built into tough durable milled aluminium enclosures that can be mounted in any plane, but should not be exposed to rain etc. as the enclosure and connectors do not meet the relevant IP ratings.

If IP65, 67 or 68 is required then an additional enclosure will be required, details of suitable enclosures are covered in the following pages.

## 6.5.1 SRT DIMENSIONS

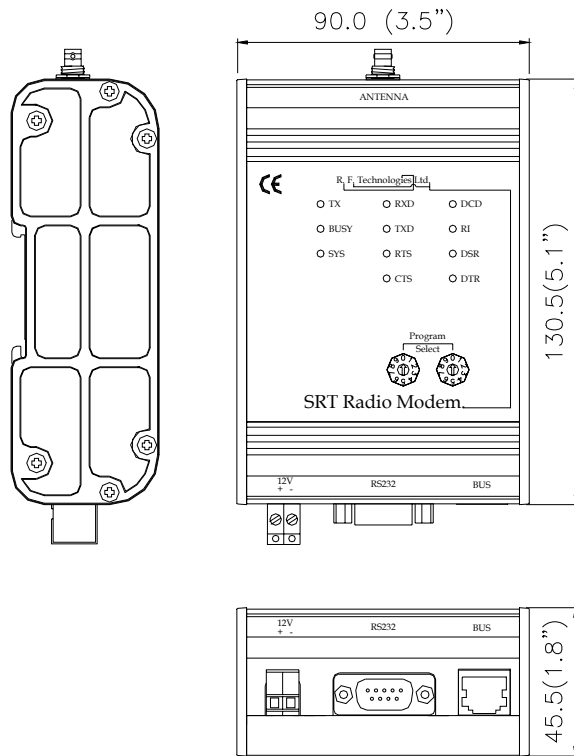

### 6.5.2 SRT MOUNTING

The SRT Series can be DIN rail mounted or panel mounted with the optional mounting bracket.

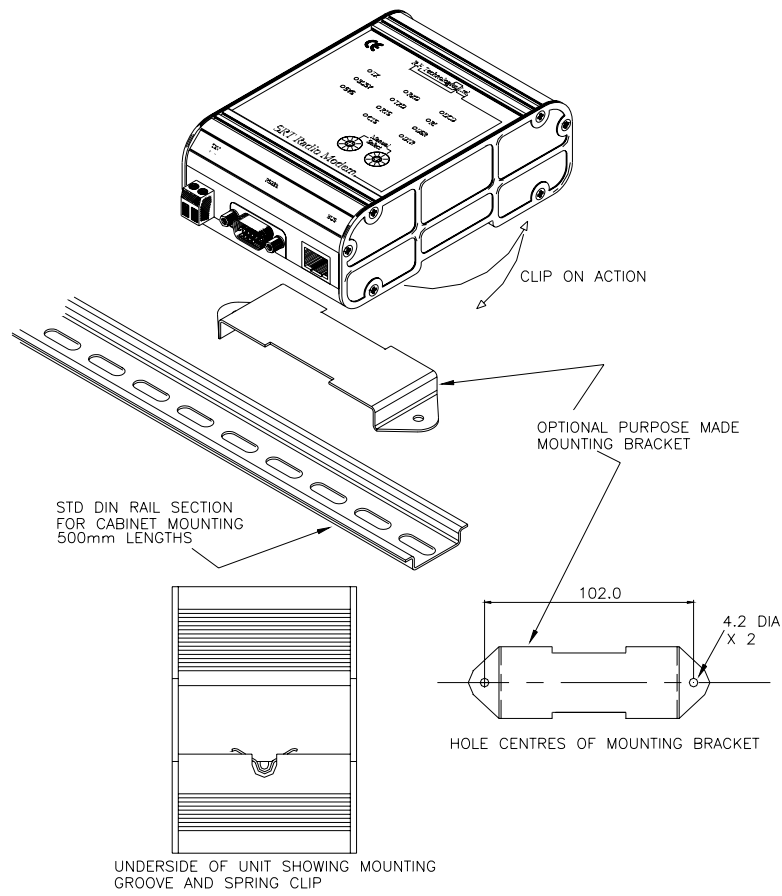

### 6.5.3 ANTENNA CONNECTION THROUGH AN ENCLOSURE:

When an SRT is used within an enclosure, the coax antenna cable can either be brought out via a suitable gland or via the "N" type adapter kit shown above.  
For IP68 installations, please consult the office for different enclosures.

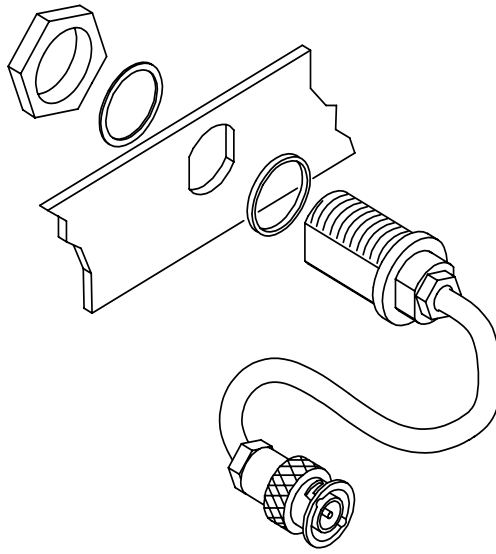

### 6.5.4 WALL MOUNTING ENCLOSURE

The wall mounting enclosure has space for an SRT MODEM, power supply and re-chargeable battery.

