



ZRT SERIES RADIO MODEMS

SETUP, INSTALLATION & OPERATING MANUAL





CONTENTS

1	INTRODUCTION	4
1.1	PRODUCTS COVERED	4
1.2	IMPORTANT NOTICES	4
2	PRODUCT OVERVIEW	5
2.1	GENERAL.....	5
2.2	TRANSMITTER.....	5
2.3	RECEIVER.....	5
2.4	MPU CONTROL.....	6
2.5	PROGRAMMING & CONFIGURATION.....	6
2.6	SOFT MODEM:.....	6
2.7	MODES OF OPERATION.....	6
2.8	ADDITIONAL FEATURES.....	6
3	SPECIFICATIONS	8
3.1	TECHNICAL SPECIFICATIONS	8
3.2	APPROVALS AND LICENSING	10
4	PRE-PROGRAMMED CHANNEL PLANS	11
4.1	UK MPT1411/VNS2111 CHANNELS.....	11
4.2	UK MPT1329 CHANNELS	13
5	SETUP & INTERFACING	14
5.1	INTERNAL CONSTRUCTION.....	14
5.2	INTERFACE PORT PIN CONNECTIONS	14
5.3	12VDC POWER	15
5.4	ANTENNA PORT	15
5.5	CHANNEL SWITCHES	15
5.6	PROGRAMMING.....	16
5.7	RF POWER.....	16
5.8	TIME-OUT-TIMER	16
5.9	INTERNAL MODEM.....	17
5.10	RADIO DATA FORMATS.....	17
5.11	FORWARD ERROR CORRECTOR	18
5.12	SQUELCH TAIL (DRIBBLE BITS) ELIMINATION	18
5.13	SERIAL INTERFACE & HANDSHAKING	18
5.14	TRAFFIC PROTOCOLS	19
5.15	TRANSMIT & RECEIVE TIMING.....	20
5.16	POWER CONSUMPTION	23
5.17	POWER SAVE MODE.....	23
5.18	“RSSI” RECEIVE SIGNAL STRENGTH INDICATION.....	23
5.19	STATUS LEADS	24
6	INSTALLATION	25
6.1	INTRODUCTION.....	25
6.2	POWER SUPPLIES	25
6.3	EFFECTIVE RADIATED POWER (ERP).....	25
6.4	ANTENNAS, COAX FEEDERS & PERIPHERALS	26
6.5	MOUNTING & INSTALLATION	28
6.6	FIXING DETAILS.....	28

1 INTRODUCTION

1.1 PRODUCTS COVERED

This manual covers the ZRT Series of low cost, high performance radio modems designed for data applications in commercial and industrial systems.

The ZRT is an advanced, simplex/half-duplex, data radio for transparent transmission of serial data. Versions are available with three different serial port configurations:-

- A true RS232 interface with speeds and data formats fully programmable.
- As above but with 5V TTL voltage levels on the interface rather than RS232 levels.
- An RS422/RS485 interface.

Information is provided to assist with configuration, installation, and operation of the products in point to point or point to multi-point applications. A separate programming manual covers the use of the associated WinA4P software for programming and configuration of the radios.

Component level servicing is not covered in this document; if the product fails its first line testing it should be returned to a service centre.

1.2 IMPORTANT NOTICES

1.2.1 Copyright

All rights to this manual are the sole property of R.F. Technologies Ltd. The copying of the manual in whole or in part by any method without written permission is strictly prohibited.

1.2.2 Right To Change

In the interest of improvement, R.F. Technologies reserves the right to change the technical specifications or functions of its product without notice.

1.2.3 Software

R.F. Technologies Ltd software is delivered "as is". R.F. Technologies Ltd does not grant any kind of warranty or guarantees on its saleability or it's suitability for use in specific applications.

Under no circumstances is R.F. Technologies liable for any damages arising from using the software.

The copyrights relating to all software is the sole property of R.F. Technologies Ltd.

Any copying, editing, translating or modifying is strictly forbidden without prior written consent from R.F. Technologies Ltd

1.2.4 Safety Critical Applications

The ZRT has not been designed for, nor is it intended for, use in safety critical or life support applications. No functional warranty is given if the product is used in such applications.

1.2.5 Use

The ZRT radio modems have been designed to work on various licensed and license-free frequency bands in use around the world. In the license-free bands, the user must ensure that the radio modem is used under the terms & conditions applicable to the use of the bands concerned.

In licensed bands, the user must obtain permission and the necessary licenses from the relevant authorities.

2 PRODUCT OVERVIEW

2.1 GENERAL

The ZRT Series has been designed as a range of high specification, low cost radio modems for stand alone applications or for integration into OEM products.

Through the use of advanced DSP technology, the design has been optimised for reliability and low current consumption, making the ZRT suitable for operation on remote sites without mains power.

Applications include security, command & control, data logging, SCADA, telemetry, remote switching or any similar applications where serial data needs to be transmitted.

The ZRT is available with three different serial interfaces:-

- An RS232 interface with all signalling lines to allow full handshaking if required.
- A TTL version of the unit which uses 5V TTL voltage levels on the serial interface connector rather than RS232 signalling levels, but is otherwise the same.
- A version with an RS422/RS485 interface. In addition to the balanced data lines, this version also has single ended RTS and DTR control lines for added flexibility.

The data rate on the serial interface can set to a range of values from 150 baud to 38,400 baud, while the over-air data rate can be independently set to a range of values between 150 baud and 9,600 baud. If high throughput speeds are not required, the modem can be set to a slower over-air rate to take advantage of the associated improvement in receiver threshold.

The ZRT is available with two different transmit powers. The low power version meets the licence-exempt ETS300-220 specification while the higher power 5W version meets the tougher ETS300-113 and the USA and Canadian specifications.

2.2 TRANSMITTER

The transmitter frequency can be user programmed anywhere within it's pre-aligned bandwidth. There are two power versions available, 10mW to 750mW and 50mW to 5W. The transmit power of any particular hardware version can be set accurately within the relevant range under software control.

2.3 RECEIVER

The receiver is a very low current double conversion superheterodyne with an active balanced mixer for very good intermodulation performance. Careful attention to spurious response, adjacent channel and blocking performance, makes the product ideal for crowded telemetry channels.

To achieve high performance the programmable bandwidth of the receiver has been limited (for UHF it is 12MHz, \pm 6MHz from centre frequency), full details are in the technical specification section.

Should re-alignment be required, the unit can be returned to our service centre.

2.4 MPU CONTROL

The Microprocessor (MPU) is the heart of the product and at the centre is a 128k flash microprocessor that controls all the interface circuits to the radio module and external input/outputs. As well as the control functions, the processor provides DSP functionality that enables modem operation between 150 and 9,600bps. The processor has 128k of flash memory from which the code is executed and internal EEPROM for storing programmed parameters.

2.5 PROGRAMMING & CONFIGURATION

The parameters of the ZRT are PC programmable via the serial port. Full details of all the programmable parameters are covered in the separate programming manual. Details of cables and adaptors needed for the various interface versions are given in Section 5.6.

2.6 SOFT MODEM:

The ZRT has a "soft modem" which allows over-air transmission at rates between 150bps and 9,600bps using a range of different modulation schemes. The over-air rate can be selected by the operator to optimise link performance.

2.7 MODES OF OPERATION

The ZRT can operate transparently without packetising the data and without adding any other overheads, thereby maximising data throughput rates. It requires no knowledge of the data it is transmitting. Data is simply transmitted and received with minimal delay.

On the RS232 and TTL versions, transmission control can either use RTS control signals or be configured for automatic initiation of transmission on receipt of serial data at the traffic interface.

In either case, the radio provides a CTS output which can optionally be used for flow control. The radio incorporates an internal buffer to cope with situations where the interface data rate is higher than the over-air rate.

On the RS422/RS485 version, RTS/CTS handshaking should never be activated using the configuration software. Transmission is automatic when transmit data is applied. There is an RTS control line which can optionally be used to force the receive side to stop outputting data if there is a lot of received interference blocking the bus and preventing transmissions in 2-wire mode.

2.8 ADDITIONAL FEATURES

The ZRT incorporates the following additional features which enhance the usability of the product and assist with the operation and maintenance of systems using the product:-

2.8.1 Status LEDs:

The ZRT Radio Modems have a number of front panel LED's to enable the operator to see at a glance the status of the product and the serial data port.

2.8.2 Time-out Timer

The transmitter within the ZRT has a user programmable time-out timer which allows the maximum continuous transmission time to be set in order to prevent channel blocking due to a fault.

2.8.3 Power-Save Modes

The ZRT has both internally controlled and externally controlled power-save modes to reduce overall power consumption to extremely low levels for operation on sites without mains power.

2.8.4 Squelch Tail Elimination

As a user programmable option, the ZRT can also operate in a packetisation mode where framing characters are added at the start and end of the user's message prior to transmission and stripped off again at the receive end prior to passing the user data to the interface connector. This can be useful in getting rid of any spurious characters which may otherwise be generated at the end of messages by squelch noise as the receiver mutes and which can affect old or non-tolerant protocols.

2.8.5 Forward Error Correction

The ZRT allows an optional forward error correction to be switched in when the over-air data rate is 9,600bps. This will improve error performance, but there is an associated data throughput overhead of around 30% which therefore reduces the effective transmission rate for the user data. The forward error corrector is not available at lower data rates as it offers no significant performance enhancement at these lower rates.

3 SPECIFICATIONS

3.1 TECHNICAL SPECIFICATIONS

3.1.1 General

Frequency Range:	ZRT169/170	138 - 175MHz
	ZRT225	175 - 225MHz
	ZRT450/470	406 - 512MHz
	ZRT869	869 - 870MHz
	(50MHz - 950MHz to special order)	
Power Requirements:	12VDC (10V - 15.5DC)	
	Standby:	<75uA
	Receiver on & decoding:	<70mA
	Transmitting:	300mA to 2.1A dependent on Tx power
Number of Channels:	80 sequential or 32 discrete user programmable channels.	
Min. Programmable Channel Step:	6.25kHz or 5kHz	
Channel Spacing:	12.5kHz, 20kHz or 25kHz	
Operating Temp. Stability:	2ppm	-30 to +60°C
Construction:	Aluminium enclosure.	
Size:	75mm W x 130mm L x 30mm H (excluding brackets and connectors)	
Mounting:	Screws to a flat surface.	
Weight:	250g	
Connectors:	DC Power	2-way Klippon Type
	Serial Data	9-way D-Type Female
	RF	BNC (50 ohm)
LED Indicators:	TX, Busy, System, RXD, TXD	

3.1.2 Transmitter:

RF Output Power:	ZRT 169/450/869	10mW - 750mW
	ZRT 170/225/470	50mW - 5Watts
Bandwidth:	VHF	10MHz without re-alignment
	UHF	12MHz without re-alignment
	870	30MHz without re-alignment
Internal Modulation:	Programmable for FFSK, 2-Level FSK, GMSK or 4-Level FSK.	
Max. Deviation:	± 7.5kHz max	
Duty Cycle	up to 70%	
Adj. Channel Power:	>65dB at 12.5kHz	
Spurious Emissions:	As per ETS300-113	
Rise Time:	< 9mS	

3.1.3 Receiver

Sensitivity:	0.25uV (-119dBm) for 12dB SINAD de-emphasised 0.355uV (-117dBm) for 12dB SINAD flat
Bandwidth:	VHF 5MHz without re-alignment UHF 10MHz without re-alignment 870 20MHz without re-alignment
Spurious Response:	ZRT 169/450/869 >65dB ZRT 170/225/470 >70dB
Blocking:	ZRT 169/450/869 >85dBuV ZRT 170/225/470 >90dBuV
Intermodulation:	ZRT 169/450/869 >60dB (3 Signal) ZRT 170/225/470 >65dB (3 Signal)
Adjacent Channel:	>65dB at 12.5kHz
IF Frequencies:	45MHz and 455kHz
Spurious Emissions:	ZRT 169/450/869 <ETS 300-220 ZRT 170/225/470 <ETS 300-113
Mute Response Time:	<2msec

3.1.4 Internal Modem

Serial Comms:	Asynchronous (or Synchronous with custom software). Baud rate programmable between 150bps and 38,400bps
Interface:	Default:- RS.232 complete with signalling lines /TTL version:- 5V TTL levels rather than RS.232 /485 version:- RS.422/RS.485 (2 or 4 wire)
Parity:	Programmable as Odd, Even or None
NRZI:	On or Off
Stop bits:	Programmable 1 or 2
Data Bits:	Programmable 7 or 8
Signalling Formats:	Programmable as V23, Bell202 or MPT1327, up to 1200 baud, coherent FFSK at 2400 baud, GMSK at 4800 baud, 4 Level FSK at 9600 baud.
Synchronous/ Async:	Programmable as either up to 1200bps, synchronous above 1200bps
Over-air Baud Rate:	150 - 9600bps within 12.5kHz
Bit Error Rate:	150 - 2400 baud less than 1×10^{-3} at -120dBm 4800 baud less than 1×10^{-3} at -117dBm 9600 baud less than 1×10^{-3} at -115dBm (FEC on) 9600 baud less than 1×10^{-3} at -112dBm (FEC off)

Forward Error Corrector (FEC) is a programmable option at 9600bps.

The bit error rates quoted above are for fixed messages representing typical data sent over the link. The BER should not be directly compared with other manufactures figures unless the data format is known, as many manufacturers quote a BER based on a simple alternating data pattern, which will generally give much better BER results.

3.2 APPROVALS AND LICENSING

The ZRT has been designed to meet the relevant standards outlined below. Should others be required, please contact the sales office.

3.2.1 UK Approvals

MPT1411/VNS2111: The 5W version of the ZRT has been tested to MPT1411 and the replacement VNS2111 for licensed applications with a maximum data rate of 9600bps within a 12.5 kHz channel. A licence is required and the permitted output power is normally stated on the licence.

MPT1329: The radios meet the requirements of MPT1329

BS2011: The unit complies with the Vibration specification BS2011.

3.2.2 European Approvals

ETS 300-220 The unit meets the specification for European licensed exempt communications with a maximum RF power level of 500mW. Please note the permitted power level may vary from country to country.

ETS 300-113 The 5W version of the unit meets the specification for licensed data radios

ETS 301-489: The unit meets the required CE specification and carries a CE Mark.

EN60950 The unit meets the relevant requirements of this Safety specification.

3.2.3 European Declaration of Conformance

Hereby, RF DataTech declares that the ZRT Series of Radio Modems is in compliance with the essential requirements and other relevant provisions of Directive 1999/5/EC.



In the interest of improvement the above specifications are subject to change without notice.

4 PRE-PROGRAMMED CHANNEL PLANS

Using the PC configuration software, the ZRT can be programmed with a number of standard channel plans. These currently include all UK MPT1411 or MPT1329 channels. Further standard channel plans may become available in later releases of the configuration software. A mixture of channels from different channel plans can also be entered discretely using the software.

The following tables show the channel numbers and associated frequencies for various channel plans:-

4.1 UK MPT1411/VNS2111 CHANNELS

CHANNEL	SCANNER	OUTSTATIONS
1	457.50625	463.00625
2	457.51875	463.01875
3	457.53125	463.03125
4	457.54375	463.04375
5	457.55625	463.05625
6	457.56875	463.06875
7	457.58125	463.08125
8	457.59375	463.09375
9	457.60625	463.10625
10	457.61875	463.11875
11	457.63125	463.13125
12	457.64375	463.14375
13	457.65625	463.15625
14	457.66875	463.16875
15	457.68125	463.18125
16	457.69375	463.19375
17	457.70625	463.20625
18	457.71875	463.21875
19	457.73125	463.23125
20	457.74375	463.24375
21	457.75625	463.25625
22	457.76875	463.26875
23	457.78125	463.28125
24	457.79375	463.29375
25	457.80625	463.30625
26	457.81875	463.31875
27	457.83125	463.33125
28	457.84375	463.34375
29	457.85625	463.35625
30	457.86875	463.36875
31	457.88125	463.38125
32	457.89375	463.39375
33	457.90625	463.40625
34	457.91875	463.41875
35	457.93125	463.43125
36	457.94375	463.44375
37	457.95625	463.45625
38	457.96875	463.46875

39	457.98125	463.48125
40	457.99375	463.49375
41	458.00625	463.50625
42	458.01875	463.51875
43	458.03125	463.53125
44	458.04375	463.54375
45	458.05625	463.55625
46	458.06875	463.56875
47	458.08125	463.58125
48	458.09375	463.59375
49	458.10625	463.60625
50	458.11875	463.61875
51	458.13125	463.63125
52	458.14375	463.64375
53	458.15625	463.65625
54	458.16875	463.66875
55	458.18125	463.68125
56	458.19375	463.69375
57	458.20625	463.70625
58	458.21875	463.71875
59	458.23125	463.73125
60	458.24375	463.74375
61	458.25625	463.75625
62	458.26875	463.76875
63	458.28125	463.78125
64	458.29375	463.79375
65	458.30625	463.80625
66	458.31875	463.81875
67	458.33125	463.83125
68	458.34375	463.84375
69	458.35625	463.85625
70	458.36875	463.86875
71	458.38125	463.88125
72	458.39375	463.89375
73	458.40625	463.90625
74	458.41875	463.91875
75	458.43125	463.93125
76	458.44375	463.94375
77	458.45625	463.95625
78	458.46875	463.96875
79	458.48125	463.98125
80	458.49375	463.99375

4.2 UK MPT1329 CHANNELS

The ZRT can be programmed to operate on the full MPT1329 band of channels with access to channels 26, 27 & 32 denied, in line with MPT1329 band plan.

The radio should be programmed for a maximum power level of 500mW.

CHANNEL	FREQUENCY
1	458.5000 Guard Ch.
2	458.5125
3	458.5250
4	458.5375
5	458.5500
6	458.5625
7	458.5750
8	458.5875
9	458.6000
10	458.6125
11	458.6250
12	458.6375
13	458.6500
14	458.6625
15	458.6750
16	458.6875
17	458.7000
18	458.7125
19	458.7250
20	458.7375
21	458.7500
22	458.7625
23	458.7750
24	458.7875
25	458.8000
26	458.8125
27	458.8250 Not Used
28	458.8375 Not Used
29	458.8500
30	458.8625
31	458.8750
32	458.8875
33	458.9000 Not Used
34	458.9125
35	458.9250
36	458.9375
37	458.9500 Guard Ch.

5 SETUP & INTERFACING

5.1 INTERNAL CONSTRUCTION

The exploded view shows the main components of the radio modem. There are no user adjustments or settings which require removal of the covers other than the optional termination links in RS422/RS485 version.

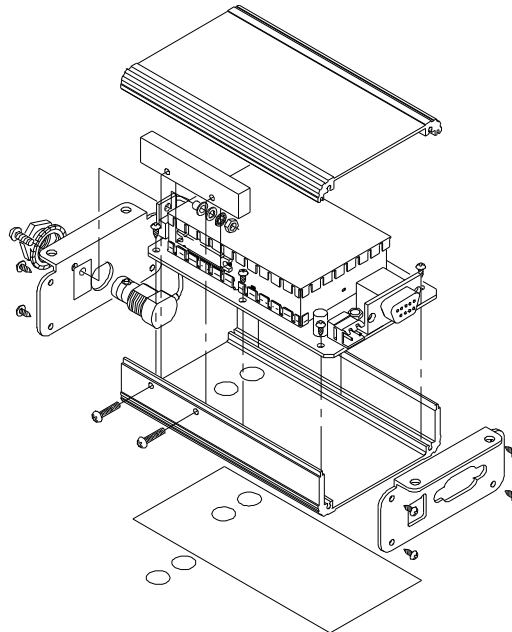

5.2 INTERFACE PORT PIN CONNECTIONS

The ZRT Series is equipped with a 9 way female D connector for the traffic interface. The pins of this connector are allocated as follows:-

5.2.1 RS232 and TTL versions

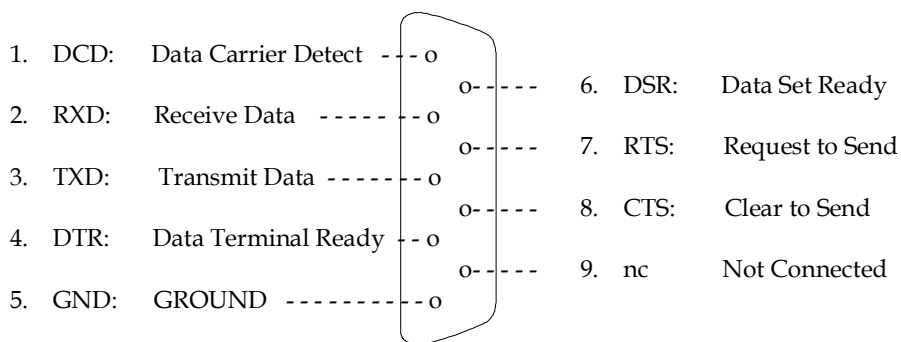

5.2.2 RS422/RS485 Versions

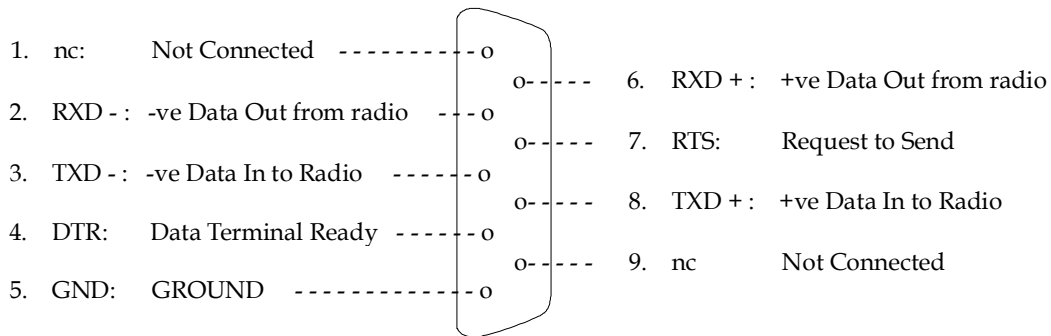

In the RS422/RS485 version, a 120 ohm terminator is fitted to the radio main circuit board, but it is not normally in circuit. To connect the terminator, a link should be fitted to the two way header situated immediately behind the 9 way D connector on the circuit board, the terminator will then be in circuit across the TXD+ and TXD- pins. In general, it is preferable to fit an external terminator rather than using this link since the use of an external termination allows the radio to be connected straight to a PC RS232 port for programming without the need to remove the terminator link.

The radio can be used in either 2 or 4 wire circuits, no configuration changes are necessary. To connect to a 2 wire circuit the TXD and RXD signals must be wired in parallel by connecting TXD- to RXD-, and TXD+ to RXD+.

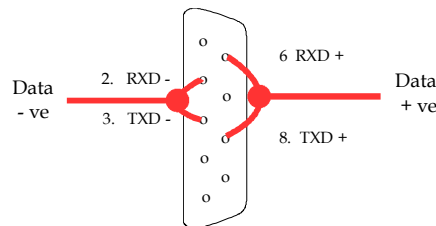

5.3 12VDC POWER

A nominal 12VDC (9.6 – 15.5Vdc) is supplied to the unit via a 2 way pluggable terminal block, the polarity is marked on the front panel and the plug has a polarity key to prevent accidental polarity reversal. In the event of a polarity reversal the circuit board is protected by diodes and fuses.

5.4 ANTENNA PORT

The antenna connection is a 50 ohm BNC connector. This should be connected to a suitable antenna or terminated in a 50 ohm load whenever the transmitter is activated. Transmission into an open circuit may cause excessive current to be drawn from the supply and damage could occur.

5.5 CHANNEL SWITCHES

The ZRT can be user programmed with up to 80 sequential or 32 discrete simplex or semi-duplex channels.

The two front panel BCD switches select the required channels or, if both are set to zero, program mode is entered. In program mode, the radio interprets any signals on the serial interface as programming commands rather than data for transmission.

When viewing a ZRT with the aerial connector at the top, the left hand rotary switch is the "tens" switch and the right is the "units" switch, thus to set channel 37, set the left switch to 3 and the right to 7.

5.6 PROGRAMMING

The parameters of the ZRT can be programmed via the serial port using either DOS or Windows based software. The individual configuration files can be stored on disc for future use or printed. Full details of all the programmable parameters are covered in the separate programming manual.

The RS232 version can be connected directly to the serial port on a PC using a straight-through cable.

The TTL version needs an adaptor unit between the ZRT and the programming computer to convert between RS232 and TTL voltage levels.

The RS422/RS485 version does not need an adaptor, but a special, straight-through programming lead using only pins 2, 3 & 5 must be used. Do **not** use a standard cable with all pins connected when programming this version. When programming RS422/RS485 version in this way, ensure that the optional internal 120 ohm termination link is not fitted. The link is generally not fitted at the factory unless specially requested.

5.7 RF POWER

The transmit power can be accurately set using a locally connected PC running the supplied configuration software. This allows the RF power level to be programmed directly in Watts or milliwatts with an accuracy of +/-1dB. There are no internal power adjustment points inside the modem.

There are two transmit power ranges available. The low power ZRT169, ZRT450 & ZRT869 versions can be set between 10mW and 750mW, while the higher power ZRT170, ZRT225 & ZRT470 versions can be set between 50mW and 5W.

5.8 TIME-OUT-TIMER

The transmitter within the ZRT has a time-out timer which allows the maximum continuous transmission time to be set in order to prevent channel blocking due to a host fault. The timer works in all modes (external/internal modem) and is programmable in one second steps between 0 and 255 seconds. If not required the timer can be programmed off.

If the timer is enabled and the selected time is exceeded, transmission will cease until the action that normally causes transmission is removed and then re-applied. More explicitly; with RTC/CTS handshake enabled RTS must be dropped and then raised again, or if handshake is not enabled character transmission must be suspended for at least two character periods at the serial port baud rate. In all modes the modem's SYS led is flashed at least twice when time-out occurs, the flashing continues while lockout is in force. The lockout timer is disabled if the lockout time is set to 0. The lockout timer can be operated in "resettable" or "cumulative" mode, in resettable mode the timer restarts each time a transmission is made, in cumulative mode the timer counts up during transmit, and down during receive. If the timer counts up to the lockout time during transmit, lockout occurs; this will eventually happen if the radio spends more than half of its time transmitting. Lockout in this mode is indefinite and can only be reset by powering the radio off.

5.9 INTERNAL MODEM

The ZRT features an internal “soft modem” which offers unparalleled performance and flexibility over a wide range of speeds and formats. Data is presented to the modem via the RS232 (or TTL) serial connection at speeds between 150 and 38400 and then transmitted at the programmed radio baud rate. Buffering is provided when the data rate is higher than the radio transmission rate.

5.9.1 Modulation & Tone-sets

Within a 12.5kHz channel, the over-air transmission from the unit can be programmed for a range of speeds. For 150, 300, 600,1200, the modulation is FFSK with Bell 202 and V.23 (Mode 2) tone-sets both supported. At these lower speeds, it is also possible to select a protocol specific MPT1327 mode which uses a 1200/1800Hz tone-set to allow compatibility with number of additional modems from other manufacturers. At 2400bps the modulation is coherent FFSK, at 4800bps it is GMSK and at 9600bps it is 4-Level FSK.

If operating at speeds up to and including 1200bps and compatibility with other equipment is not required, the use of the Bell 202 tone-set is recommended, as this will give the best link performance.

5.9.2 Synchronous/Asynchronous Modem Operation

The radio modem can be programmed for asynchronous or synchronous operation at baud rates up to 1200. At baud rates of 2400 or more, modem operation may only be synchronous. This relates to the over-air signal and has no bearing on the format of the data presented at the serial interface port

In synchronous mode inverted NRZI encoding is used where a one is represented by a transition in the binary data, every transmitted bit fits into a time slot defined by the baud rate, this allows a phase locked loop to lock on to the data stream to give better performance in noisy conditions, the inverted NRZI encoding allows this to continue even when the signal is idling sending stop bits. The inverted NRZI encoding gives a further advantage with GMSK signalling since the polarity of the signal is unimportant.

In asynchronous mode NRZ encoding is used where a “one” tone represents a binary one, and a “zero” tone a binary zero, whilst each character consists of bits of equal duration defined by the baud rate, the time between the end of a stop bit and a following start bit may be arbitrary. This prevents the implementation of a phase locked loop to improve signal to noise performance but does allow use within older systems that do not implement synchronous transmission or NRZI encoding.

If compatibility with other radios is not required, the use of the synchronous mode is recommended, as this will give best link performance.

5.10 RADIO DATA FORMATS

The data rate over the air can be set up independently of the rate set for the serial interface, but the over-air rate should be set either at the same speed or a lower speed than the serial interface rate. The radio baud rate should be set at the minimum possible to maintain the required throughput, lower speeds will give better results in poor signal conditions

The radio signal can be set up to operate using 7 or 8 bit data, 1 or 2 stop bits, and odd, even or no parity. This setting is also independent of the serial port setup. This flexibility allows compatibility with other radios.

If the Forward Error Corrector is enabled (option only available at 9,600bps), the selected radio signal format is over-ridden as detailed below.

5.11 FORWARD ERROR CORRECTOR

At 9600bps there is also a programmable option to switch in a forward error corrector. When switched on, the over-air data format changes to a fixed format using 14 bit words. These comprise 8 data bits, 5 CRC (Cyclic Redundancy Check) bits and a flag bit which is used to differentiate control and data functions in messages. An additional 14 bit synchronisation word is also sent after every 8 data words. The effect of this redundancy on a typical 9600bps link configuration is to reduce the effective data transfer rate to around 6300bps.

The error corrector is aimed at improving performance in weak signal conditions, rather than recovering data in deep fades or burst-error conditions. An error rate of 1×10^{-4} with the FEC switched off will typically improve by a factor of 2000 to around 5×10^{-7} when it is switched on, but an initial error rate of 1×10^{-3} with it off will only improve by a factor of around 250 to something like 4×10^{-5} when it is switched on.

In terms of receiver sensitivity, the 1×10^{-6} threshold improves by around 0.4uV (or 6.4dB) when the FEC is switched on.

5.12 SQUELCH TAIL (DRIBBLE BITS) ELIMINATION

The ZRT has an optional packetisation mode which can be enabled using the configuration program. This adds framing characters at the start and end of the user's message prior to transmission. The additional information is stripped off the messages at the receiver prior to passing the data to the interface connector. Packetisation can be useful in getting rid of any spurious characters which may otherwise be generated at the end of messages by squelch noise as the receiver mutes and which can affect old or non-tolerant protocols.

It is important to note that packetisation must be set the same on all radios operating together. All radios must have it selected or all radios must have it de-selected.

5.13 SERIAL INTERFACE & HANDSHAKING

On the RS422/RS485 version, the RTS/CTS handshaking setting should never be activated using the configuration software. Selection of this setting could cause problems. Transmission is automatic when transmit data is applied. There is an RTS control line which can optionally be used (without any changes to software configuration settings) to force the receive side to stop outputting data if there is a lot of received interference blocking the bus and preventing correct transmissions in 2-wire mode. On this version, the RTS input is a TTL level signal which is internally pulled up to +5V through a resistance of approximately 50k ohm and which is active low (ground pin 7 to activate). The RTS line on early models (pre February 2007) may be active high and internally pulled down to ground through a similar resistance.

The RS232 and TTL versions can be programmed either to use RTS/CTS handshaking to initiate transmission, or to transmit automatically whenever data is present at the serial input. In the latter mode CTS is still operated to implement flow control but can be ignored unless message sizes exceed 1k byte and the serial port baud rate is higher than the radio signal baud rate. These handshaking modes are compatible with modes A, C and D of the CMD400 manufactured by Pacscom Ltd.. Mode B (byte stuffing mode) is not supported.

5.13.1 RS232 & TTL Transmission Using RTS/CTS Handshaking

If handshaking is enabled, transmission is started by operating RTS. CTS can then be monitored for flow control purposes. In the idle state CTS is inactive, but when RTS is operated CTS will become active immediately and data may be input to the serial port. When all data has been loaded to the serial port RTS should be dropped. Transmission will continue until all data in the serial input buffer has been sent, then CTS will become inactive and transmission will cease. During transmission the amount of data in the serial buffer is checked by the radio, if the buffer becomes $\frac{3}{4}$ full CTS is dropped to request the host to stop loading data, CTS is activated again when the buffer is reduced to $\frac{1}{4}$ full. To prevent timing problems data will still be accepted into the buffer when CTS is de-activated due to buffer filling during transmit, however any data received once CTS has dropped at the end of a transmission will be discarded, this prevents such data from being prefixed to the beginning of the next message.

5.13.2 Transmission Without Hardware Handshaking

If RTS/CTS handshaking is disabled the radio will start transmission as soon as data is received at the serial port, transmission ceases as soon as the serial buffer has been emptied and a period equivalent to two characters at the radio signal baud rate has elapsed. It is important to note that since transmission ceases as soon as a two character delay in the incoming data stream is seen, data characters in a message must be presented in a continuous back to back stream.

In this mode CTS is still used to indicate the serial buffer fill level in the same way as described in the section on transmission using handshake, the difference is that in the idle state CTS is always active indicating readiness to accept data. In most applications CTS can be ignored as messages are likely to be smaller than the serial input buffer (1k byte), bear in mind also that if the radio baud rate and data format is the same as that configured for the serial port the buffer is being emptied as fast as it is being filled and so buffer overrun is unlikely.

5.13.3 Data Reception

Any data received by the radio is simply output to the serial port, the DCD line can be programmed to operate in three different modes to assist the host. Firstly by indicating that a carrier is detected on the radio channel, this is useful if a busy lockout function is required (although this can be dangerous if the channel is susceptible to interference as well as wanted signals), secondly DCD can indicate presence of a carrier and a valid data signal, data will normally be output under this circumstance, the third mode behaves in the same way as the second except that DCD remains active until all data has been output to the serial port after the signal has gone, this allows DCD to be used as a wake up signal.

5.14 TRAFFIC PROTOCOLS

The ZRT has no knowledge of the data it is transmitting, data is simply transmitted and received under hardware control with the option of RTS control or initiation of transmit after receiving serial data, with CTS providing an optional flow control. This configuration is useful when expanding older systems where the radios must be compatible with others of various manufacturers. If protocol specific operation or "store-and-forward" modes are required, it would be necessary to use radios from our SRT or ART ranges.

5.15 TRANSMIT & RECEIVE TIMING

The ZRT only operates in a simplex or semi-duplex mode. In simplex mode the receive and transmit frequencies are the same, whereas in the semi-duplex mode they are different. In either mode data is only sent in one direction at a time as the radios do not have separate synthesisers for transmit and receive. If full duplex mode is required (transmit & receive at the same time) the ART product should be considered.

In simplex/semi-duplex mode, the radio synthesiser must be reloaded each time Receive or Transmit is selected. Although relatively short, the synthesiser loading time must be taken into account when looking at data transfer times.

In order to reduce adjacent channel interference in line with ETS300-113, the power output from the transmitter has finite rise and fall times, a distant receiving radio will therefore see an incoming signal later than a nearby one. The receiving radio also requires time for the carrier detect circuit to operate and for the modem to lock on to the incoming audio signal.

When using the ZRT, there are a few timing considerations to be taken into account. The main one is the programmable "lead in delay", which is required for the modem to lock on to the incoming data stream and is dependant on the radio signal baud rate. Minimum timings are given below:

Baud Rate	Lead in Delay(Minimum)
150	80ms
300	60ms
600	40ms
1200	40ms
2400	40ms
4800	20ms
9600	30ms

For simplex/semi-duplex operation, time is required for the transmit and receiver synthesiser to be loaded and locked prior to transmission/reception. This timing constraint is important when deciding how soon after receiving a message a reply may be sent. For simplex/semi-duplex operation the ZRT is ready to receive data approximately 25ms after transmission ceases. It is therefore necessary to either wait this length of time after receiving a message before sending a reply or to extend the lead in delay by the same amount to hold off transmission of the data.

For applications where power save is in use the lead in delay should be extended to allow the receiving device to wake up. The time required can be calculated by adding the save on time to the save off time and adding 10 percent, e.g. for a save on time setting of 800ms and a save off time of 200ms the lead in delay should be 1100ms.

Care must be taken when replying to a previously transmitting ZRT when RTS/CTS handshake is not being used, in this mode the transmitting device will wait for two character times before turning off its carrier and may therefore miss the beginning of a reply if it comes too soon, this may be overcome either by imposing an additional two character delay in the controlling device or by extending the lead in delay by that amount.

The ZRT also has a facility for imposing a lead out delay, which is the time that the carrier remains on after transmission of the message is complete. This delay can normally be left at zero as it is only of use where a controller makes use of the DCD signal to suppress data processing but suffers some delay in processing received data, or where there is a need to delay any spurious squelch tail characters generated sufficiently that connected equipment does not confuse them with part of the message.

5.15.1 Receive To Transmit Switching Time

When using the internal modem the action that initiates transmission can be either receipt of a character at the serial port or the operation of RTS. These examples use the first mode. The radio does nothing until the stop bit of the first character for transmission has been received, the transmitter is then started:

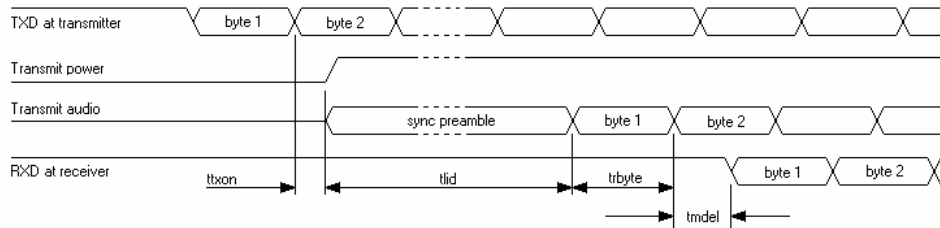

The time delay between receipt of the stop bit for the first character to be transmitted at the transmitting radio and output of the start bit of that character at the receiving radio is the sum of the values ttxon, tlid, trbyte, and tmdel shown in the diagram above. Values for these parameters are indicated below:

TABLE A: Timing values for duplex and simplex modes are as follows:

symbol	Description	Semi-duplex	simplex
ttxon	Time from external action to commencing transmission	9ms	9ms
tlid	Duration of synchronisation transmission (lead in delay)	Table B	Table B
trbyte	Duration of 1 byte at radio signal baud rate	Table C	Table C
tmdel	Modem decode latency	Table D	Table D

TABLE B: The lead in delay is a programmable parameter but minimum values dependant on baud rate must be adhered to. However, in a scanning system with the base station on continuous transmit the base station lead in delay can be set for Zero (thereby saving valuable time) as the internal outstation modems will always be synchronised.

Baud	150	300	600	1200	2400	4800	9600
Min tlid	80ms	60ms	40ms	40ms	40ms	20ms	30ms

TABLE C: The duration of a byte at the radio baud rate is dependant upon the data format employed, the table below assumes a format of one start bit, 8 data bits, no parity and 1 stop bit, i.e. a total of 10 bits per character. If another format is used the appropriate correction must be made.

Baud	150	300	600	1200	2400	4800	9600
trbyte	66.7ms	33.3ms	16.7ms	8.3ms	4.17ms	2.08ms	1.04ms

TABLE D: The modem decode latency takes into account delays introduced by hardware and software filters. The total delay is baud rate dependant:

Baud	150	300	600	1200	2400	4800	9600
tmdel	6.9ms	3.5ms	1.7ms	1.3ms	1ms	1ms	1ms

5.15.2 Message Duration

The time taken to transmit a message can be simply derived by multiplying the number of characters in a message by the values given in table C making any appropriate corrections for data format. The exception is 9600 baud where extra synchronisation sent during the message must be taken into account, 8 synchronisation bits lasting a total of 0.833ms are sent after every eighth message character.

5.15.3 Transmit To Receive Switching Time

In full or semi-duplex operation transmit to receive switching time does not need to be considered as the receive path is maintained during a transmission, in simplex operation some time must be allowed to reload the transmitter synthesiser to stop it from interfering with the receiver. The diagram below indicates the minimum time in which the radio is able to receive a signal after completing a transmission.

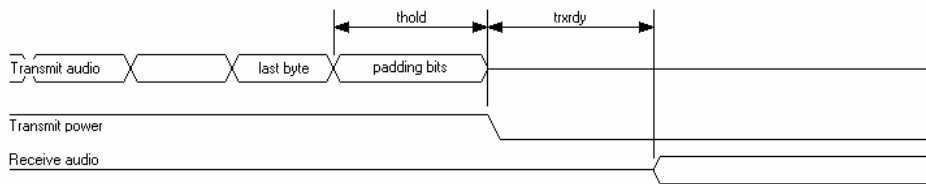

symbol	Description	value
thold	Period for which carrier is held up after sending last data byte	2.5ms + LOD
txrdy	Time to reload transmit synthesiser in simplex mode	6ms

During the time thold the radio transmits some padding bits to allow for propagation delays in the receiving device before shutting off the carrier, this prevents possible chopping of the message tail. The time thold is composed of a fixed 2.5ms period plus the programmable value LOD (lead out delay). LOD is normally set to zero. After the time txrdy has expired the radio is ready to receive a new signal.

N.B. If RTS/CTS handshaking is not used the transmitter is turned on whenever data is received at the serial port, the transmitter is left on until all buffered data has been transmitted and no data has been input for a time equivalent to the length of two characters at the radio baud rate (refer to table C). In general data transmitted by the radio is delayed with respect to its receipt at the serial port by the receive to transmit switching time, if the radio baud rate and serial port baud rate and both data formats are the same this delay remains constant throughout the transmission. At the higher baud rates this delay is generally greater than the length of two characters and so the procedure to stop transmission is started as soon as the last character has been sent, at the lower baud rates however it is possible that the time thold is extended while the radio waits for the two character timeout to expire, this can also happen if data characters are not loaded back to back into the serial port.

5.16 POWER CONSUMPTION

The ZRT is a very low power product and is ideal for operation from batteries with solar power backup. The information below is intended to help the user decide on the best battery and solar cell size for operation at non powered sites.

5.16.1 Transmitter RF power verses current

TX Power	5W	4W	3W	2W	1W	500mW	200mW	100mW	50mW
Max. Current	2.1A	1.8A	1.6A	1.3A	950mA	675mA	500mA	390mA	300mA

5.17 POWER SAVE MODE

The ZRT is equipped with an internal and external power save mode. These are outlined below:

5.17.1 Internal Power Save

In this mode the microprocessor switches the transceiver off and after a pre-programmed time (Save on time) switches the unit back on (Save off time). If a carrier is not detected then the transceiver again switches off. If during the time the transceiver is awake a carrier is received, the unit will stay on. After the carrier drops out the receiver will stay on until the programmed resume time elapses. Once the resume time has elapsed the unit will return to its power save mode. The Save On/Off and Resume time are all programmable via the PC program. Obviously the amount of power saved increases with the programmed save on/off ratio, however with power save enabled long lead times must be programmed to wake up the unit before communication can take place. Therefore it may not be possible to run all applications under the power save mode due to the turn around times required by the host system. In some circumstances it is possible to achieve power save and fast polling: If polling of all outstations is carried out in cycles with a reasonable gap between each cycle, a long initial poll can be used to wake up all stations, the resume timer will then restart each time an outstation is polled allowing fast access, when the cycle is complete all stations will return to power save after the resume time has expired.

5.17.2 External Power Save

Under this mode the on/off ratio is controlled externally via the DTR line (DTR shut down must first be enabled using the set up program). In this mode more of the modem's circuits are shutdown (including the microprocessor), this saves more power but care must be taken to ensure that the modem is enabled when a transmission is to take place. Note that there is a hardware link option to allow the serial port to shut off when DTR is not active; this allows the radio current to be reduced to its bare minimum. In applications where DTR is not connected this link option must of course be disabled.

5.18 "RSSI" RECEIVE SIGNAL STRENGTH INDICATION

The ZRT produces an internal DC signal which is proportional to the received signal strength. The DC signal is passed to the internal MPU where it accurately measures its value by an internal A-D converter. The radios are individually calibrated during production so that signal strength can then be read in dB micro volts on a PC connected to the serial port.

5.19 STATUS LEDS

The ZRT has a number of LEDs to enable the operator to see at a glance the status of the product and the serial port:-

RX RF Carrier Detect/Busy
TX Transmit
SYS System
RXD Receive Data
TXD Transmit Data

5.19.1 System LED

With the Exception of the System LED the remainder are self explanatory. The System LED lights when the radio is being programmed and is also used as a quick check as to the status of the unit. If any alarms are detected it will flash out an Error number.

5.19.2 Error Number

The modem reports errors in two ways, firstly the BUSY led will come on and the SYS led will flash a number of times, the BUSY led will then go out again and if the fault persists the procedure will be repeated. An error number can be determined by counting the number of times the SYS led flashes while the BUSY led is on.

<u>ERROR No</u>	<u>FAULT</u>
1	Position of the channel switches has changed.
2	A channel has been loaded that has no RX frequency programmed.
3	Transmission has been attempted on a channel that has no TX frequency programmed.
4	The receiver synthesiser phase locked loop has failed to lock due to bad channel data or programming of an out range frequency.
5	The transmitter synthesiser phase locked loop has failed to lock due to bad channel data or programming of an out range frequency.
6	The contents of the microprocessor's EEPROM are corrupted (failed checksum) in the general program area.
7	Internal comms with a high power amplifier have failed.
8	The contents of the microprocessor's EEPROM are corrupted (failed checksum) in the calibration area.
9	The contents of the microprocessor's EEPROM are corrupted (failed checksum) in the factory program area.
10	No POCSAG message stored for repeat test.
11	Rotary channel switch position overridden by software.
12	Tx power setting out of range.
13	Packet Mode cycle pointer invalid.
14	Bad routing table area EEPROM checksum.
15	I ² C Bus initialisation error.

6 INSTALLATION

6.1 INTRODUCTION

Correct installation of the ZRT radios should ensure reliable data communications for many years. The most important installation points to remember are:-

- Suitable antenna system mounted at the correct height & polarisation to achieve the required distance.
- Reliable power supply capable of supplying the correct voltage and current.
- Correct installation for the environment.
- Correct interface and set-up.

Assuming the unit has been correctly installed and tested at the correct data speed, other factors that may affect the performance include the RF power (normally specified by the regulating authority), the local topography and the weather.

6.2 POWER SUPPLIES

The ZRT can be powered from any power source provided that the voltage is between 9.6VDC & 16VDC with a -ve GND. If a +ve GND system is in use, an isolated converter will be required.

The ZRT requires a supply capable of providing between 300mA and 2.5A depending on the maximum transmit power required.

Under no circumstances should the output of the supply rise above 16VDC.

For 240/110VAC, 50VDC or 24VDC, a range of uninterruptible power supply units are available with a in-built charger and power fail indication. A range of suitable Gel type batteries is available should a back-up supply be required during power failures.

6.3 EFFECTIVE RADIATED POWER (ERP)

The Radio Frequency (RF) Power allowed can be specified in two ways:

- The "Terminated power into 50 ohms", which in the case of the ZRT would be a maximum of 5W.
- The "ERP", which is the actual radiated power, taking into account the gain/loss of the antenna and loss in the feeder. Hence, if we use an aerial with a gain of 3dB (x2) and assume no loss in the cable, the ERP with an input of 5W would be 10W.

The gain of an antenna is very useful as it enables lower power transmitters to be used in many cases in place of high power transmitters, with the advantage of a much lower current consumption.

For example if the ERP allowed for a link is 5W, then a ZRT operating at 5W into a unity gain antenna, would require a supply current of 2.1Amps to provide an ERP of 5W.

If however, we use an 8 element directional Yagi with a Gain of 10dB, we would only need 500mW of RF Power for the same performance.

With a ZRT operating at 500mW, the current consumption would only be 600mA. If the site is battery or solar powered then the saving is very significant.

Care must be taken when setting the power within a MPT1329/1411 system, as permitted RF power is specified as a maximum ERP.

6.4 ANTENNAS, COAX FEEDERS & PERIPHERALS

6.4.1 Antennas

Apart from the radio modem, the antenna is probably the most important part of the system. The wrong choice or a bad installation will almost certainly impede the product's performance. Depending on the application either an omni-directional or directional antenna will be required.

6.4.2 Types of Antennas

We can offer a complete range of antennas to suit all applications; details of some of the more popular ones are outlined below:-

<u>Antenna Types</u>	<u>Typical Gain</u>	<u>Polarisation</u>	<u>Use</u>
Vertical Whip	0dB	Vertical	In-house testing and local use
Helical	- 3dB	Vertical	
End Fed Dipole	0dB	Vertical	Local Scanner or Multi-point system
Folded Dipole	0dB	Vertical/Horizontal	
6dB Co-linear	+6dB	Vertical	Wide area Scanner
3dB Co-linear	+3dB	Vertical	
12 Element Yagi	+12dB	Vertical/Horizontal	Outstation or point to point link
4 Element Yagi	+8dB	Vertical/Horizontal	
Corner Reflector	+10dB	Vertical/Horizontal	Outstations in areas of bad Interference or where radiation must be kept to a minimum
Patch Antenna	0dB	Vertical/Horizontal	Kiosk or Wall mounting

6.4.3 Directional Antennas

For point to point communications, a directional Yagi or corner reflector is probably the best type of antenna to use, as directional antennas provide relatively high gain in the forward direction within a limited beamwidth and very good rejection of unwanted signals at the rear. The number of elements and hence the size, will depend on the gain and beam width required. Yagi antennas can be used in the vertically polarised or horizontally polarised, but communicating products should be fitted with antennas of the same polarisation. If not a loss of signal strength will occur. Use of both vertical and horizontal propagation can be very useful on single or repeater sites where isolation is required between communication paths. Using differently polarised antennas for each path will increase the isolation which will reduce possible interference between the paths.

6.4.4 Omni-Directional Antennas

With approximately 360 degree radiation pattern, this type of antenna is ideal for the central site of a scanning station or where communication to a group of widely dispersed outstations is required.

6.4.5 Patch or Plate Antennas

The patch or plate antennas are normally rectangular or round, with a back plate of aluminium or stainless steel. A polycarbonate or ABS cover is fitted to protect the antenna from the environment. This type of antenna can be produced in different sizes with various radiation patterns to suit the application. Depending on the construction and radiation pattern, the gain is usually between -3dB to + 3dB. Their use is very popular on road side kiosks, buses, trains, aircraft, or where covert communication is required.

6.4.6 Antenna Mounting

Location: The antenna should be mounted in a clear area, as far away as possible from obstructions such as metal constructions, buildings and foliage.

Height: The ZRT operates in the UHF band, which requires near line of sight communication. Hence, for extended ranges the height of the antenna is important.

6.4.7 Polarisation

A Yagi or corner reflector antenna can be mounted for vertical or horizontal polarisation. Scanning systems employing a vertically polarised antenna will necessitate the outstation antennas to be of the same orientation. In vertical polarisation the elements are perpendicular to the ground. By mixing polarisation within systems, unwanted signals can be reduced by as much as 18dB. However, such systems require detailed planning.

6.4.8 Alignment

If a directional antenna is to be used, it will need alignment with the scanner or communicating station. A map and compass can be used, but the final adjustment should be performed by measuring the receive signal strength (RSSI) from the scanner, as outlined in the operations section.

6.4.9 Antenna Coax Feeder:

As with the antenna, the use of the wrong coax feeder can seriously affect the performance of the system. Hence, the coax cable should be selected to give a low loss over the distance required. For outstations in the local vicinity of the scanner/ base station, the loss is not very important but for distant stations the loss is very important. As a rule of thumb, never operate a system with a loss of more than 3dB.

To illustrate the point, a 3dB loss in the feeder will result in a 50% loss in transmitted RF power and a 50% reduction in the received signal strength. Therefore, double the received signal strength will be required for the same bit error rate. Although increasing the RF power will compensate for the loss in transmitted power, there is no effective way to improve the received signal strength.

Coax cable should be installed in accordance with the manufacturers' instructions, with cable runs kept as short as possible. Sharp bends, kinks and cable strain must be avoided at all costs. If long term reliability is required, the cable must be securely mounted to avoid excessive movement and longitudinal strain, due to high winds, rain and snow.

6.4.10 Signal Loss v. Cable Length at 500MHz

Cable Type	Attenuation per 100ft	Attenuation per 100m
RG58	13.0dB	37.0dB
RG213	6.0dB	17.5dB
LDF2-50 3/8inch Foam Helix	2.44dB	8.0dB
LDF4-50 1/2inch Foam Helix	1.60dB	5.26dB
LDF5-50 7/8inch Foam Helix	0.883dB	2.9dB
LDF6-50 1-1/4inch Foam Helix	0.654dB	2.15dB
LDF7-50 1-5/8inch Foam Helix	0.547dB	1.79dB

6.4.11 Coax & Connectors:

50 Ohm coax connectors of a good quality should be used, termination must be in accordance with the manufacturer's specification, any special tools required to terminate the connectors must be used. Connectors exposed to the environment should be sealed to prevent the ingress of moisture. If the cable is penetrated by water a high loss will occur and the cable will need to be replaced. Once assembled it is advisable to test the cable and connectors for open and short circuits.

6.4.12 VSWR Measurement:

Voltage standing wave ratio (VSWR) is the ratio of detected volts from the forward RF power, to the detected volts from the reflected (returned) RF power. This ratio is used to measure the combined coax cable and antenna match. A good match will ensure that most of the RF Power is radiated, whereas a bad match will result in the reflection of a large amount of the power, thereby reducing the transmitter's range. A perfect match will give a 1:1 ratio and bad match will give 2:1 or higher. For guidance, a good system will measure between 1.2:1 and 1.5:1.

6.4.13 Lightning Arresters

At high or exposed sites, the use of a lightning arrester is recommended. This in-line device fits between the antenna and the product with an earth strap connected to ground. Should a lightning strike occur, most of the energy should be diverted to ground leaving the equipment with little or no damage.

6.5 MOUNTING & INSTALLATION

The ZRT is built into tough durable aluminium enclosure that can be mounted in any plane, but should not be exposed to rain etc. as the enclosure and connectors do not meet the relevant IP ratings.

If IP65, 67 or 68 is required then an additional enclosure will be required. A number of suitable enclosures are available as options.

6.6 FIXING DETAILS

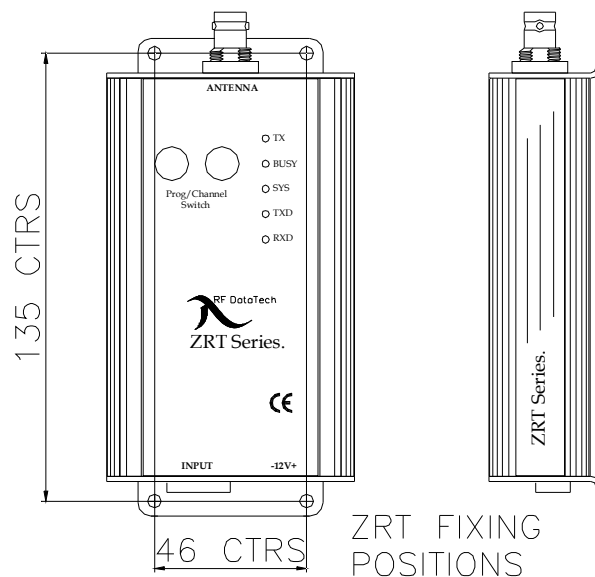



RF DataTech
is a trading division of:-

R.F. Technologies Ltd
27 - 29 New Road
Hextable
Kent BR8 7LS

Tel: +44 (0) 1322 614 313
Fax: +44 (0) 1322 614 289

E-Mail: sales@rfdatatech.co.uk

ADDITIONAL PRODUCT DATA
www.rfdatatech.co.uk